

The background of the entire page is a dense, light red overlay of technical line drawings of various industrial valves, including gate valves, globe valves, and check valves, shown in cross-section and perspective views.

POWELL **VALVES**

FORGED STEEL API 602 VALVES

GATE, GLOBE AND CHECK VALVES

API 602 / API RP 591 / ASME CLASS 800 TO 4500 / 1/4" TO 2"

Table of Contents

<u>SUBJECT</u>	<u>PAGE</u>
THE WM. POWELL COMPANY — PROFILE	2-3
HOW TO ORDER	4
FUGITIVE EMISSIONS	5
GATE VALVES	6-9
GLOBE VALVES	10-13
Y-PATTERN GLOBE VALVES	14-16
PISTON CHECK VALVES	17-20
SWING CHECK VALVES	21-24
Y-PATTERN PISTON CHECK VALVES	25-27
CRYOGENIC VALVES	28
BELLOSEAL VALVES	29
ENGINEERING DATA	30-45
TERMS AND CONDITIONS	46-48

The Wm. Powell Company - Profile

The Wm. Powell Company is very proud of our achievements and our evolution in the past 165 years. We like to refer to ourselves as 166 years young due to our flexibility in changing quickly to our customer and the industry's needs. Our business strategy is to maintain excellent customer service. We will continue to focus on manufacturing the best of class products both in design features and quality, at competitive prices.

The Wm. Powell Company's products include a wide variety of valves in bronze, iron, steel, and corrosion resistant alloys for class 125 to class 4500 pressure service. Our experience as pioneer in the development of industrial valves encompasses over a century and a half of craftsmanship and valve know-how. Through modern engineering, laboratory, research and testing facilities, the Wm. Powell Company has been a leader in changes in our industry. Our on-going program is a long-term commitment to the valve industry and is poised for significant future growth.

Powell Valves has endured a Civil War, World Wars I and II, and the Korean and Vietnam Wars. Powell rebuilt after floods, U.S. economic disaster in the Great Depression, and fierce foreign competition to help put men on the moon. Whether it was the "Manhattan Project", projects on U.S. Nuclear Submarines, Titan or Atlas rockets, in Nuclear Power plants, at Chemical or Petroleum plants, Pulp and Paper mills, or the harshness of cryogenic use, Powell Valve has a long tradition of quality in temperatures from - 425°F to 1500°F and pressures from Class 125 to 4500.

Powell's market base is the Industrial Users: Petrochemical, Industrial Gas, Pulp & Paper, Pharmaceutical, Hydrocarbon processing, Food processing, Mining, Power Generation, Pipeline, Chemical, and Mechanical construction. Powell has formed business partnerships with industrial end-users, contractors, distributors and A&E's in the United States and around the World. Business partnerships formed on competitively priced product, on-time delivery, service and our tradition of product reliability.

Powell's network of support and product availability is unmatched. Powell offers the most complete multi-turn product line from a single source manufacturer. Powell's products are of the highest quality standards, are competitively priced and are produced with modern manufacturing technology and astute materials sourcing, with strategic purchasing & financial ventures in place.

Powell's diverse products and services, industry knowledge, project capabilities and reputation, coupled with our high quality distribution network, create a win-win arrangement where the end-user, contractor, distributor and manufacturer can benefit.

The Wm. Powell Company has made a commitment to our industry to increase growth and market share, with quality competitive products and services and on-time delivery. This is a global commitment.

Powell's end user customers have to react quickly to the demands that are on them to expand their businesses by implementing increased capacity and introducing new products into the market place at low costs and fast turn around times. Powell has addressed our customer's needs by increasing finished product inventory to over \$35,000,000 USD in the U.S.A. and with inventory hubs in Asia and Europe. As an additional advantage to our domestic and global customers, The Wm. Powell Company's Manning, SC facility is a Registered Free Trade Zone.

Powell also used its valve knowledge and expertise to construct a modification facility in the U.S.A. to assist customers with their needs, such as, automation, trim changes, end connection changes, additional quality inspections and special service pressure testing requirements, field service, etc...

The Wm. Powell Company is a closely held private corporation that has been in business since 1846. In fact, only nine presidents have led the Company through its 166, plus, years. The fact that we have been a healthy corporation during this period of time, having survived wars, depressions and natural disasters – in a very competitive marketplace – speaks well for itself.

We look forward to further discussing ways that The Wm. Powell Company can capture current and future opportunities together.

Again, The Wm. Powell Company thanks you for your interest in our company, our products and services. Powell looks forward to discussing ways to be your Preferred Valve Supplier. If you should have any questions, or comments, please contact us.

Sincerely,

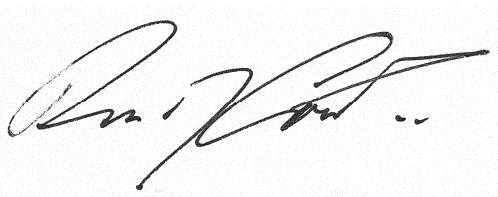
A handwritten signature in black ink, appearing to read "Randy Cowart", is written over a light gray rectangular background.

Randy Cowart

President, CEO & Chairman

The Wm. Powell Company

Powell Forged Valve Coding System

NOTE: Other configurations available upon request.

Digit

1	2	3	4	5	6	7	8	9	10	11	12	13	14	15
Size				Space	Type	Class	Ends	Material	Trim	Bonnet				
1	.	0	0	G	A	0	8	T	A	5	8	G	G	B

Example: 1.00 GA08TA58GB for a 1" Standard Port Class 800, Threaded End, A105, Trim 8, Bolted Bonnet Gate Valve with Graphite Packing and Gasket

Type	Pressure Class	Ends	Material	Trim
GA Gate	Standard Port 150#	T Threaded	A5 A105	0 API Trim 10
GL Globe	Full Port 150#	S Socketweld	04 A182 304	1 API Trim 1
PC Spring Piston Check	Standard Port 300#	X Th X Sw ⁽¹⁾	16 A182 316	2 API Trim 12
	Full Port 300#	F Flanged	21 A182 321	3 API Trim 13
BC Spring Ball Check	Standard Port 600#	R Ring Joint	47 A182 347	5 API Trim 5
	Full Port 600#	Y Inlet Th X Outlet Sw	4H A182 304H	6 API Trim 16
SW Swing Check	Standard Port 800#	Z Inlet Sw X Outlet Th	4L A182 304L	8 API Trim 8
GY Y Globe	Full Port 800#	A Sw X Ext Sw ⁽¹⁾	6L A182 316L	9 API Trim 9
	Standard Port 1500#	B Sw X Ext Th ⁽¹⁾	L2 A350-LF2	Base Metal w/ Half Hard Facing
AN Angle	Full Port 1500#	D Th X Ext Sw ⁽¹⁾	A2 Alloy 20	Base Metal w/ Full Hard Facing
BG Bellows Gate	Full Port 1500#	E Th X Ext Th ⁽¹⁾	40 Alloy N04400	
BL Bellows Globe	Standard Port 1690#	K Th X Ext WOL ⁽¹⁾	F1 A182 F11	Base Metal
YL Y Spring Piston Check	Full Port 1690#	P Sw X Ext WOL ⁽¹⁾	F2 A182 F22	
IG ISRS Gate	2500#		F4 A182 F44	API Trim 11
IL ISRS Globe	2680#		F5 A182 F5	
	4500#		51 A182 F51	API Trim 2

Type	Pressure Class	Ends	Material	Trim
01 Standard Port 150#	Standard Port 150#	T Threaded	A5 A105	0 API Trim 10
L1 Full Port 150#	Full Port 150#	S Socketweld	04 A182 304	1 API Trim 1
03 Standard Port 300#	Standard Port 300#	X Th X Sw ⁽¹⁾	16 A182 316	2 API Trim 12
L3 Full Port 300#	Full Port 300#	F Flanged	21 A182 321	3 API Trim 13
06 Standard Port 600#	Standard Port 600#	R Ring Joint	47 A182 347	5 API Trim 5
L6 Full Port 600#	Full Port 600#	Y Inlet Th X Outlet Sw	4H A182 304H	6 API Trim 16
08 Standard Port 800#	Standard Port 800#	Z Inlet Sw X Outlet Th	4L A182 304L	8 API Trim 8
L8 Full Port 800#	Full Port 800#	A Sw X Ext Sw ⁽¹⁾	6L A182 316L	9 API Trim 9
15 Standard Port 1500#	Standard Port 1500#	B Sw X Ext Th ⁽¹⁾	L2 A350-LF2	Base Metal w/ Half Hard Facing
L5 Full Port 1500#	Full Port 1500#	D Th X Ext Sw ⁽¹⁾	A2 Alloy 20	Base Metal w/ Full Hard Facing
16 Standard Port 1690#	Standard Port 1690#	E Th X Ext Th ⁽¹⁾	40 Alloy N04400	
L7 Full Port 1690#	Full Port 1690#	K Th X Ext WOL ⁽¹⁾	F1 A182 F11	Base Metal
25 2500#	2500#	P Sw X Ext WOL ⁽¹⁾	F2 A182 F22	
26 2680#	2680#		F4 A182 F44	API Trim 11
45 4500#	4500#		F5 A182 F5	

Type	Pressure Class	Ends	Material	Trim
W Welded Bonnet	Standard Port 150#	T Threaded	A5 A105	0 API Trim 10
B Bolted Bonnet Std. Bolting	Full Port 150#	S Socketweld	04 A182 304	1 API Trim 1
C Bolted Bonnet w/A193 B8M Cl.2 and A194 8M	Standard Port 300#	X Th X Sw ⁽¹⁾	16 A182 316	2 API Trim 12
D Bolted Bonnet w/A193 B8 Cl.2 and A194 8	Full Port 300#	F Flanged	21 A182 321	3 API Trim 13
E Bolted Bonnet A193 B8M and A194 8M	Standard Port 600#	R Ring Joint	47 A182 347	5 API Trim 5
F Bolted Bonnet, Std. Bolting, Clean for Oxygen	Full Port 600#	Y Inlet Th X Outlet Sw	4H A182 304H	6 API Trim 16
N Bolted Bonnet w/ A193 B7M and A194 2HM (NACE) ^[2]	Standard Port 800#	Z Inlet Sw X Outlet Th	4L A182 304L	8 API Trim 8
G Std. Extended Bolted Bonnet, Std. Bolting, Clean for Oxygen	Full Port 800#	A Sw X Ext Sw ⁽¹⁾	6L A182 316L	9 API Trim 9
H Std. Extended Welded Bonnet, Clean for Oxygen	Standard Port 1500#	B Sw X Ext Th ⁽¹⁾	L2 A350-LF2	Base Metal w/ Half Hard Facing
J Welded Bonnet, Clean for Oxygen	Full Port 1500#	D Th X Ext Sw ⁽¹⁾	A2 Alloy 20	Base Metal w/ Full Hard Facing
L Bolted Bonnet, Locking Device	Full Port 1500#	E Th X Ext Th ⁽¹⁾	40 Alloy N04400	
K Welded Bonnet (NACE) ^[2]	Standard Port 1690#	K Th X Ext WOL ⁽¹⁾	F1 A182 F11	Base Metal
M Bolted Bonnet A193 B8 and A194 8 (NACE) ^[2]	Full Port 1690#	P Sw X Ext WOL ⁽¹⁾	F2 A182 F22	
R Ring Joint Bonnet.	2500#		F4 A182 F44	API Trim 11
	2680#		F5 A182 F5	
	4500#		51 A182 F51	API Trim 2

Bonnet And Bolting	
W	Welded Bonnet
B	Bolted Bonnet Std. Bolting
C	Bolted Bonnet w/A193 B8M Cl.2 and A194 8M
D	Bolted Bonnet w/A193 B8 Cl.2 and A194 8
E	Bolted Bonnet A193 B8M and A194 8M
F	Bolted Bonnet, Std. Bolting, Clean for Oxygen
N	Bolted Bonnet w/ A193 B7M and A194 2HM (NACE) ^[2]
G	Std. Extended Bolted Bonnet, Std. Bolting, Clean for Oxygen
H	Std. Extended Welded Bonnet, Clean for Oxygen
J	Welded Bonnet, Clean for Oxygen
L	Bolted Bonnet, Locking Device
K	Welded Bonnet (NACE) ^[2]
M	Bolted Bonnet A193 B8 and A194 8 (NACE) ^[2]
R	Ring Joint Bonnet.

Packing & Gasket	
G	Manuf. STD Graphite
T	Manuf. STD Teflon

1. Only To be Used For Gate Valves.

2. API Trim 10 or 12 can also be used for NACE service valves If Bonnet And Bolting codes N, K, or M are Selected. Make Sure to select A NACE Bonnet and Bolting Designation if a NACE valve is required.

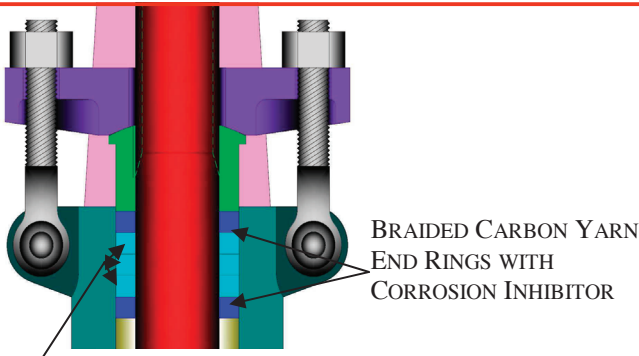

DIE FORMED FLEXIBLE GRAPHITE RIBBON INNER RINGS WITH CORROSION INHIBITOR

BRAIDED CARBON YARN END RINGS WITH CORROSION INHIBITOR

STANDARD PACKING ARRANGEMENT

Powell standard design cast steel valves are designed and manufactured to a 100 ppm maximum fugitive emissions level.

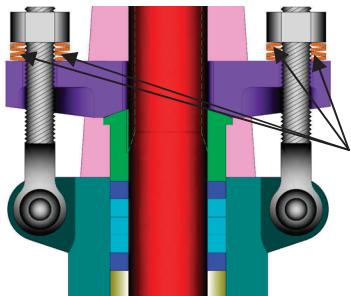

BELLEVILLE WASHERS

LIVE LOAD

Live load design with standard packing. Live load washers help maintain packing load to reduce frequency of packing adjustment.

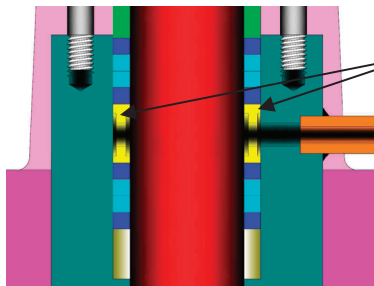

LANTERN RING

LANTERN RING

Lantern ring design and other special packing arrangements available. The lantern ring arrangement consists of two packing sets with lantern spacer between the sets. The bonnet connection at the lantern ring location allows monitoring of leakage past packing set.

GASKETS

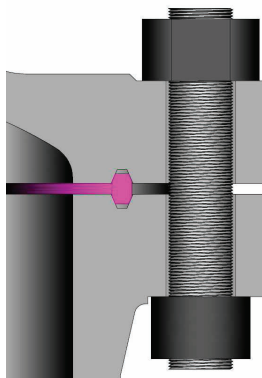

RING JOINT

ASME B16.20 ring joint gasket with material at least equal to body. Standard gasket arrangement for class 2500 and higher class valves. Optionally available on most other valves.

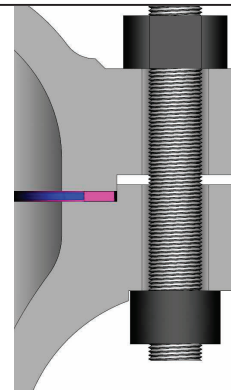

SPIRAL WOUND

Stainless steel spiral wound gasket with graphite fill. Standard gasket arrangement for class 150-1500 valves.

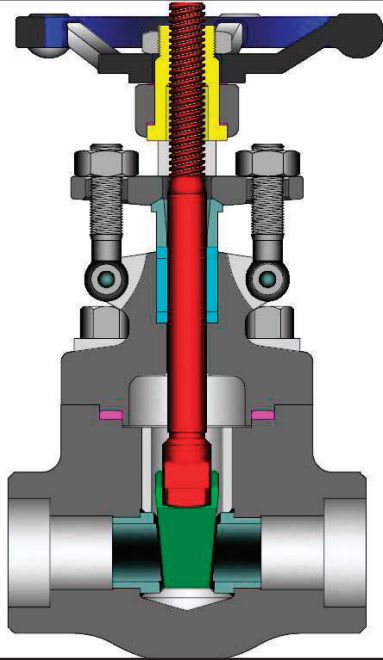

Class	Bore	Fig. No.
150	Standard	GA01
	Full	GAL1
300	Standard	GA03
	Full	GAL3
600	Standard	GA06
	Full	GAL6
800	Standard	GA08
	Full	GAL8
1500	Standard	GA15
	Full	GAL5
1680	Standard	GA16
2500	Standard	GA25
2690	Standard	GA26

DESIGN FEATURES:

- **Wedges** are accurately guided thru the entire stroke.
- **Standard trim** is stellite faced seat rings, 13% chrome wedge seat surfaces, and 13% chrome stem (API trim 8). Other trims available on request.
- **Seat faces** lapped for smooth finish and superior sealing.
- **Stems** are non-rotating with surface finish to maximize packing seal for low fugitive emissions.
- **Each** valve is shell, seat and back-seat pressure tested per industry standard API 598.
- **Gland** is two piece gland / gland flange design for optimal alignment and uniform packing compression.

STANDARD MATERIALS (Other materials available)

PART	MATERIALS			
Body	A105	A182 F11	A182 F22	A182F316 (1)
Bonnet	A105	A182 F11	A182 F22	A182 F316
Wedge	SST 420			A182 F316
Seat Ring	SST 410 + Stellite 6 Faced			SST 316
Stem	A182 F6a			A182 F316
Stem Bushing	A 439 Ductile NI-Resist Gr. D2			
Gland Flange	A105			Series 300 SST
Eye Bolt	A193 Gr. B7	A193 Gr. B16		A193 Gr. B8M
Eye Bolt Nut	A194 Gr. 2H	A194 Gr. 7		A194 Gr.8M
Gland	SST 420			SST 316
Packing	Graphite			PTFE
Packing Washer / Packing Spacer	SST 410			SST 316
Gasket (2)	Spiral Wound SST with Graphite			Spiral Wound SST with PTFE
Hand Wheel	Malleable Iron or Steel			
Hand Wheel Nut	Malleable Iron or Steel			
Key	Steel			
Body / Bonnet Bolting (2)	A193 Gr. B7	A193 Gr. B16		A193 Gr. B8M
Identification Plate	Series 300 SST			

- (1) Threaded and weld end valve bodies A182 F316L
- (2) Welded bonnet design also available.

NOTE: See page 43 for flow, safety and maintenance information.

- **End Flanges** have the following raised faces per ASME B16.5:
Classes 150-300: 1/16” (2mm).
Classes 600: 1/4” (7mm).
- **Weld ends** are available per ASME B16.25/B16.11 or per customer’s specification.
- **Extended** body ends available on gate valves.
- **Other** available options as follows:
-Alternate valve materials such as chrome and stainless steel alloys
-Alternate trim materials
-NACE service
-Special cleaning for applications such as oxygen or chlorine
-Other options available as specified.

Design Specifications

Item	Applicable Specification
Wall thickness	API 602
Pressure - temperature ratings	ASME B16.34
General valve design	API 602 & B16.34
End to End dimensions	ASME B16.10
Flange design	ASME B16.5
Thread design	ASME B1.20.1
Butt Weld design	ASME B16.25
Socket Weld design	ASME B16.11
Materials	ASTM

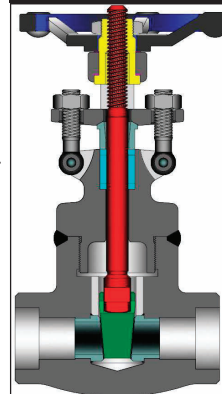

Welded Bonnet Design

GATE VALVE DIMENSIONS (CLASS 150—800).

SIZE	ASME 150				ASME 300				ASME 600			
	Bolted Bonnet				Bolted Bonnet				Bolted Bonnet			
	Standard Bore				Standard Bore				Standard Bore			
in	A	C	D	E	A	C	D	E	A	C	D	E
mm	FE				FE				FE			
½	4.25	6.0	0.50	3.9	5.50	6.0	0.50	3.9	6.50	6.0	0.50	3.9
13	108	153	13	100	140	153	13	100	165	153	13	100
¾	4.62	6.0	0.50	3.9	6.00	6.0	0.50	3.9	7.50	6.0	0.50	3.9
19	117	153	13	100	152	153	13	100	190	153	13	100
1	5.00	7.3	0.71	4.9	6.50	7.3	0.71	4.9	8.50	7.3	0.71	4.9
25	127	185	18	125	165	185	18	125	216	185	18	125
1¼	5.50	8.7	0.94	6.3	7.00	8.7	0.94	6.3	9.00	8.7	0.94	6.3
32	140	222	24	160	178	222	24	160	229	222	24	160
1½	6.50	9.4	1.14	6.3	7.50	9.4	1.14	6.3	9.50	9.4	1.14	6.3
38	165	240	29	160	190	240	29	160	241	240	29	160
2	7.00	11.0	1.46	7.1	8.50	11.0	1.46	7.1	11.50	11.0	1.46	7.1
50	178	279	37	180	216	279	37	180	292	279	37	180

SIZE	ASME 800															
	Bolted Bonnet								Welded Bonnet							
	Standard Bore				Full Bore				Standard Bore				Full Bore			
in	A	C	D	E	A	C	D	E	A	C	D	E	A	C	D	E
mm	WE				WE				WE				WE			
¼	3.11	5.9	0.31	3.9	-	-	-	-	3.11	6.2	0.31	3.9	-	-	-	-
6	79	149	8	100	-	-	-	-	79	157	8	100	-	-	-	-
¾	3.11	5.9	0.39	3.9	-	-	-	-	3.11	6.2	0.39	3.9	-	-	-	-
10	79	149	10	100	-	-	-	-	79	157	10	100	-	-	-	-
½	3.11	6.0	0.50	3.9	3.62	6.0	0.50	3.9	3.11	6.3	0.50	3.9	3.62	6.3	0.50	3.9
13	79	153	13	100	92	153	13	100	79	161	13	100	92	161	13	100
¾	3.62	6.0	0.50	3.9	4.37	7.3	0.71	4.9	3.62	6.3	0.50	3.9	4.37	7.5	0.71	4.9
19	92	153	13	100	111	185	18	125	92	161	13	100	111	190	18	125
1	4.37	7.3	0.71	4.9	4.72	8.7	0.94	6.3	4.37	7.5	0.71	4.9	4.72	8.7	0.94	6.3
25	111	185	18	125	120	222	24	160	111	190	18	125	120	220	24	160
1¼	4.72	8.7	1.14	6.3	4.72	9.4	1.14	6.3	4.72	8.7	1.14	6.3	4.72	9.4	1.14	6.3
32	120	222	29	160	120	240	29	160	120	220	29	160	120	240	29	160
1½	4.72	9.4	1.14	6.3	5.51	11.0	1.46	7.1	4.72	9.4	1.14	6.3	5.51	11.0	1.46	7.1
38	120	240	29	160	140	279	37	180	120	240	29	160	140	279	37	180
2	5.51	11.0	1.46	7.1	6.30	13.1	1.89	7.9	5.51	11.0	1.46	7.1	6.30	12.6	1.89	7.9
50	140	279	37	180	160	333	48	200	140	279	37	180	160	319	48	200

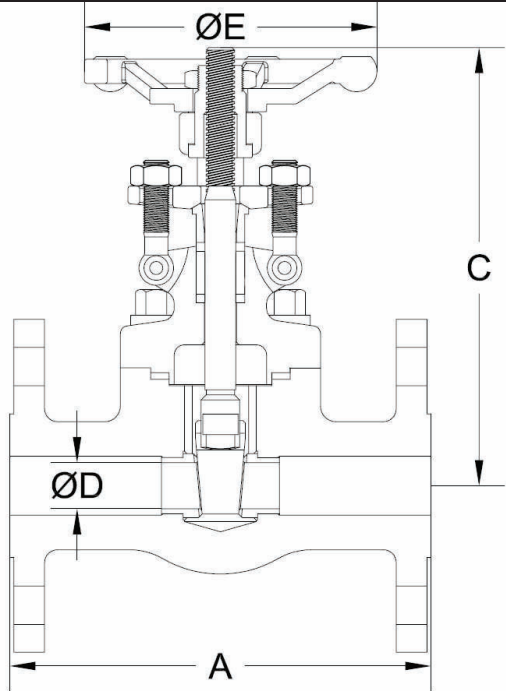

Bolted Bonnet Flanged Ends Design

ADDITIONAL MATERIALS AND CLASSES AVAILABLE UPON REQUEST.

WE = Socket Weld / Threaded Ends
 FE = Flanged ends
 C = Center to top open

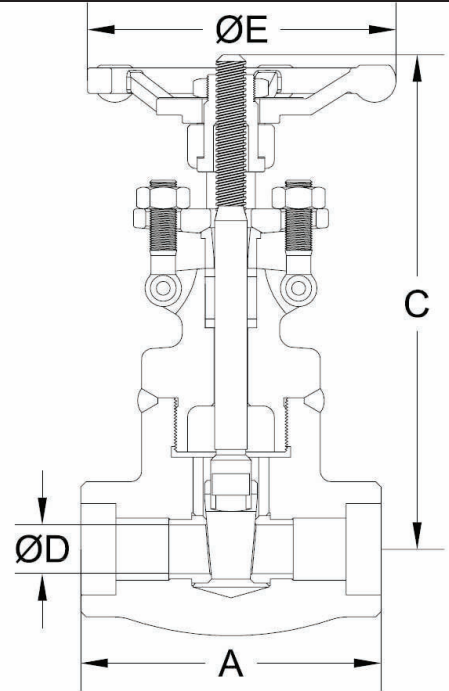

Welded Bonnet Socket Weld Ends Design

GATE VALVE DIMENSIONS (CLASS 1500—2680).

SIZE	ASME 1500 & 1690																
	Bolted Bonnet									Welded Bonnet							
	Standard Bore					Full Bore				Standard Bore				Full Bore			
in	A		C	D	E	A	C	D	E	A	C	D	E	A	C	D	E
mm	FE	WE				WE				WE				WE			
¼	-	3.11	6.9	0.31	3.9	-	-	-	-	3.11	6.9	0.31	3.9	-	-	-	-
6	-	79	175	8	100	-	-	-	-	79	175	8	100	-	-	-	-
¾	-	3.62	7.0	0.50	3.9	-	-	-	-	3.62	6.9	0.50	3.9	-	-	-	-
10	-	92	178	13	100	-	-	-	-	92	175	13	100	-	-	-	-
½	8.50	3.62	7.1	0.50	4.9	4.37	7.1	0.50	4.9	3.62	7.1	0.50	4.9	4.37	7.1	0.50	4.9
13	216	92	181	13	125	111	181	13	125	92	181	13	125	111	181	13	125
¾	9.00	4.37	7.1	0.50	4.9	4.72	8.6	0.71	6.3	4.37	7.1	0.50	4.9	4.72	8.6	0.71	6.3
19	229	111	181	13	125	120	218	18	160	111	181	13	125	120	218	18	160
1	10.00	4.72	8.6	0.71	6.3	4.72	9.3	0.94	6.3	4.72	8.6	0.71	6.3	4.72	9.3	0.94	6.3
25	254	120	218	18	160	120	237	24	160	120	218	18	160	120	237	24	160
1¼	11.00	4.72	9.3	0.94	6.3	5.51	10.8	1.14	7.1	4.72	9.3	0.94	6.3	5.51	10.8	1.14	7.1
32	279	120	237	24	160	140	274	29	180	120	237	24	160	140	274	29	180
1½	12.00	5.51	10.8	1.14	7.1	6.30	12.6	1.46	7.9	5.51	10.8	1.14	7.1	6.30	12.6	1.46	7.9
38	305	140	274	29	180	160	319	37	200	140	274	29	180	160	319	37	200
2	14.50	6.30	12.6	1.46	7.9	9.1	13.6	1.89	7.9	6.30	12.6	1.46	7.9	9.1	13.6	1.89	7.9
50	368	160	319	37	200	230	345	48	200	160	319	37	200	230	345	48	200

SIZE	ASME 2500 & 2680								
	Bolted Bonnet					Welded Bonnet			
	Standard Bore					Standard Bore			
in	A	C	D	E	A	C	D	E	
mm	WE				WE				
½	5.91	11.2	0.55	6.3	5.91	10.0	0.55	6.3	
13	150	284	14	160	150	253	14	160	
¾	5.91	11.2	0.55	6.3	5.91	10.0	0.55	6.3	
19	150	284	14	160	150	253	14	160	
1	6.69	12.9	0.75	7.9	6.69	11.5	0.75	7.9	
25	170	327	19	200	170	291	19	200	
1¼	7.87	14.7	1.00	9.8	7.87	13.3	1.00	9.8	
32	200	374	25	250	200	339	25	250	
1½	7.87	14.8	1.10	9.8	7.87	13.5	1.10	9.8	
38	200	377	28	250	200	342	28	250	
2	9.84	17.1	1.38	11.8	9.84	15.7	1.38	11.8	
50	250	434	35	300	250	398	35	300	

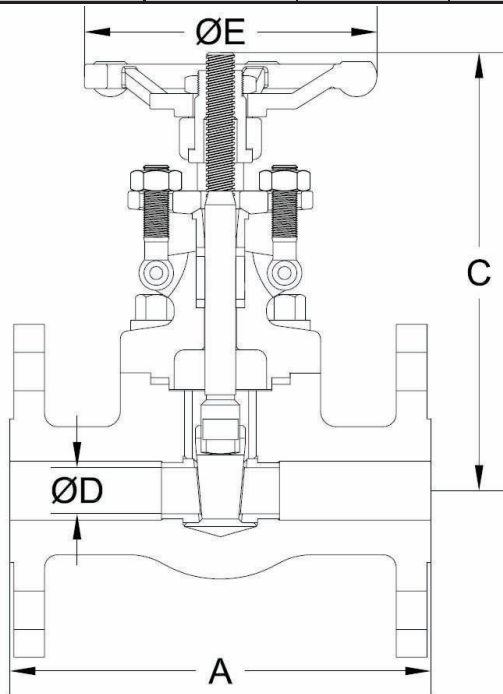

Bolted Bonnet Flanged Ends Design

ADDITIONAL MATERIALS AND CLASSES AVAILABLE UPON REQUEST.

WE = Socket Weld / Threaded Ends
FE = Flanged Ends

C = Center to top open

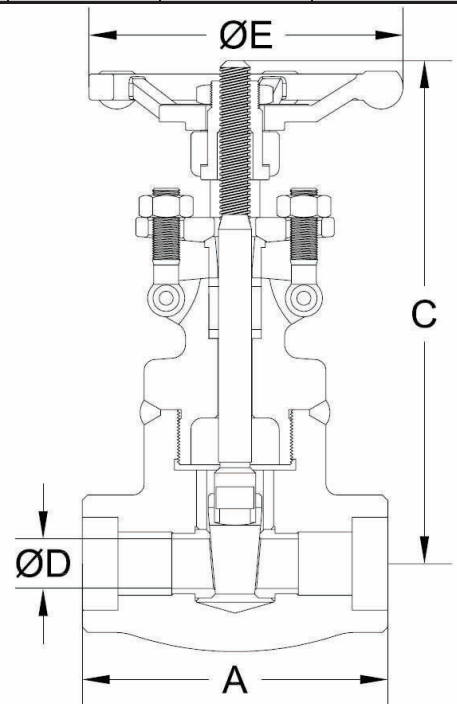

Welded Bonnet Socket Weld Ends Design



API 602 GATE VALVES
 FORGED CARBON , STAINLESS STEEL OR ALLOY STEEL
 ¼” TO 2” (6 TO 50 mm)
 ASME CLASSES 150 TO 2680

SIZE	ASME 150			ASME 300			ASME 600			ASME 800											
	Bolted Bonnet			Bolted Bonnet			Bolted Bonnet			Bolted Bonnet						Welded Bonnet					
	Standard Bore			Standard Bore			Standard Bore			Standard Bore			Full Bore			Standard Bore			Full Bore		
in	WT	LB	C _v	WT	LB	C _v	WT	LB	C _v	WT	LB	C _v	WT	LB	C _v	WT	LB	C _v	WT	LB	C _v
mm	FE	KG		FE	KG		FE	KG		WE	KG		WE	KG		WE	KG		WE	KG	
¼	-	-	-	-	-	-	-	-	-	4.2	5	-	-	3.7	5	-	-	-	-		
6	-	-	-	-	-	-	-	-	-	1.9	-	-	-	1.7	-	-	-	-	-		
¾	-	-	-	-	-	-	-	-	-	4.2	8	-	-	3.7	8	-	-	-	-		
10	-	-	-	-	-	-	-	-	-	1.9	-	-	-	1.7	-	-	-	-	-		
½	6.6	13	-	7.9	13	-	9.3	13	-	4.4	13	7.3	13	4.0	13	7.1	13	-	-		
13	3.0	-	-	3.6	-	-	4.2	-	-	2.0	-	3.3	-	1.8	-	3.2	-	-	-		
¾	7.7	13	-	10.8	13	-	12.8	13	-	4.9	13	8.4	25	4.4	13	8.2	25	-	-		
19	3.5	-	-	4.9	-	-	5.8	-	-	2.2	-	3.8	-	2.0	-	3.7	-	-	-		
1	12.1	30	-	15.4	30	-	19.4	30	-	7.9	30	12.8	45	7.5	30	12.6	45	-	-		
25	5.5	-	-	7.0	-	-	8.8	-	-	3.6	-	5.8	-	3.4	-	5.7	-	-	-		
1¼	15.0	70	-	20.7	70	-	26.7	70	-	13.7	70	14.8	70	11.7	70	14.6	70	-	-		
32	6.8	-	-	9.4	-	-	12.1	-	-	6.2	-	6.7	-	5.3	-	6.6	-	-	-		
1½	22.9	70	-	29.3	70	-	34.4	70	-	13.7	70	22.7	110	13.2	70	22.5	110	-	-		
38	10.4	-	-	13.3	-	-	15.6	-	-	6.2	-	10.3	-	6.0	-	10.2	-	-	-		
2	31.7	120	-	39.7	80	-	43.0	120	-	21.4	120	33.5	220	20.9	120	33.3	220	-	-		
50	14.4	-	-	18.0	-	-	19.5	-	-	9.7	-	15.2	-	9.5	-	15.1	-	-	-		

SIZE	ASME 1500 & 1690												ASME 2500 & 2680							
	Bolted Bonnet						Welded Bonnet						Bolted Bonnet			Welded Bonnet				
	Standard Bore			Full Bore			Standard Bore			Full Bore			Standard Bore			Standard Bore				
in	WT	LB	WT	LB	C _v	WT	LB	C _v	WT	LB	C _v	WT	LB	C _v	WT	LB	C _v	WT	LB	C _v
mm	FE	KG	WE	KG		WE	KG		WE	KG		WE	KG		WE	KG		WE	KG	
¼	-	-	6.6	-	5	-	-	-	6.2	5	-	-	-	-	-	-	-	-	-	
6	-	-	3.0	-	-	-	-	-	2.8	-	-	-	-	-	-	-	-	-	-	
¾	-	-	7.1	13	-	-	-	-	6.6	13	-	-	-	-	-	-	-	-	-	
10	-	-	3.2	-	-	-	-	-	3.0	-	-	-	-	-	-	-	-	-	-	
½	15.9	-	7.7	13	-	9.5	13	-	7.3	13	9.3	13	21.6	20	15.0	20	-	-	-	
13	7.2	-	3.5	-	-	4.3	-	-	3.3	-	4.2	-	9.8	-	6.8	-	-	-	-	
¾	25.4	-	8.8	13	-	13.9	25	-	8.2	13	13.7	25	22.0	20	15.4	20	-	-	-	
19	11.5	-	4.0	-	-	6.3	-	-	3.7	-	6.2	-	10.0	-	7.0	-	-	-	-	
1	34.4	-	13.2	25	-	16.1	45	-	12.6	25	15.9	45	49.6	25	22.0	25	-	-	-	
25	15.6	-	6.0	-	-	7.3	-	-	5.7	-	7.2	-	22.5	-	10.0	-	-	-	-	
1¼	35.7	-	15.4	45	-	24.7	70	-	14.8	45	24.5	70	69.9	55	43.4	55	-	-	-	
32	16.2	-	7.0	-	-	11.2	-	-	6.7	-	11.1	-	31.7	-	19.7	-	-	-	-	
1½	49.8	-	23.8	70	-	35.1	110	-	23.1	70	34.8	110	70.5	70	57.3	70	-	-	-	
38	22.6	-	10.8	-	-	15.9	-	-	10.5	-	15.8	-	32.0	-	26.0	-	-	-	-	
2	62.2	-	34.2	120	-	36.4	220	-	33.5	120	36.2	220	83.8	120	69.9	120	-	-	-	
50	28.2	-	15.5	-	-	16.5	-	-	15.2	-	16.4	-	38.0	-	31.7	-	-	-	-	

FE = Flanged Ends
WE = Socket Weld / Threaded Ends

WT = Weight
C_v = Flow Coefficient

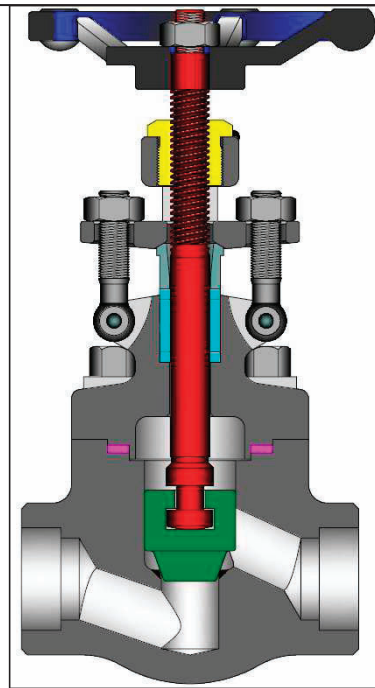

STANDARD MATERIALS (Other materials available)

PART	MATERIALS			
Body	A105 + Stellite 6 Faced	A182 F11 + Stellite 6 Faced	A182 F22 + Stellite 6 Faced	A182 F316 (1)
Bonnet	A105	A182 F11	A182 F22	A182 F316
Disc	SST 420			A182 F316
Stem	A182 F6a			A182 F316
Gland Flange	A105			A182 F316
Eye Bolt	A193 Gr. B7	A193 Gr. B16		A193 Gr. B8M
Eye Bolt Nut	A194 Gr. 2H	A194 Gr. 7		A194 Gr. 8M
Gland	SST 420			Series 300 SST
Packing	Graphite			PTFE
Gasket (2)	Spiral Wound SST with Graphite			Spiral Wound SST with PTFE
Hand Wheel	Malleable Iron or Steel			
Hand Wheel Nut	Malleable Iron or Steel			
Body / Bonnet Bolting (2)	A193 Gr. B7	A193 Gr. B16		A193 Gr. B8M
Identification Plate	Series 300 SST			

Class	Bore	Fig. No.
150	Standard	GL01
	Full	GLL1
300	Standard	GL03
	Full	GLL3
600	Standard	GL06
	Full	GLL6
800	Standard	GL08
	Full	GLL8
1500	Standard	GL15
	Full	GLL5
1680	Standard	GL16
2500	Standard	GL25
2690	Standard	GL26

- (1) Threaded and weld end valve bodies A182 F316L
- (2) Welded bonnet design also available.

NOTE: See page 43 for flow, safety and maintenance information.

Design Specifications

Item	Applicable Specification
Wall thickness	API 602
Pressure - temperature ratings	ASME B16.34
General valve design	API 602 & B16.34
End to End dimensions	ASME B16.10
Flange design	ASME B16.5
Thread design	ASME B1.20.1
Butt Weld design	ASME B16.25
Socket Weld design	ASME B16.11
Materials	ASTM

DESIGN FEATURES:

- **Standard trim** is stellite faced seats integral to the body, 13% chrome disc, and 13% chrome stem (API trim 8). Other trims available on request.
- **Wall thickness** per heavy wall API 602 requirements.
- **Seat faces** lapped for smooth finish and superior sealing.
- **Swivel disc** for optimal seating and longer seat life are non-rotating.
- **Stems** of hand wheel operated design are rotating / rising design.
- **Each valve** is shell, seat and backseat pressure tested per industry standard API 598.
- **Gland** is two piece gland / gland flange design for optimal alignment and uniform packing compression.

- **End Flanges** have the following raised faces per ASME B16.5:
Classes 150-300: 1/16” (2mm)
Classes 600: 1/4” (7mm)
- **Weld ends** are available per ASME B16.25/ B16.11 or per customer’s specification.
- **Other** available options as follows:
-Alternate valve materials such as chrome and stainless steel alloys
-Alternate trim materials
-NACE service
-Special cleaning for applications such as oxygen or chlorine
-Other options available as specified

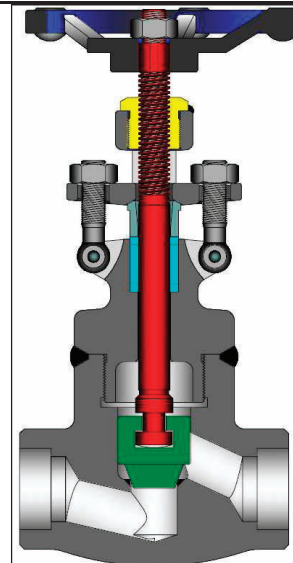

Welded Bonnet Design

GLOBE VALVE DIMENSIONS (CLASS 150—800).

SIZE	ASME 150				ASME 300				ASME 600			
	Bolted Bonnet				Bolted Bonnet				Bolted Bonnet			
	Standard Bore				Standard Bore				Standard Bore			
in	A	C	D	E	A	C	D	E	A	C	D	E
mm	FE				FE				FE			
½	4.25	6.0	0.39	3.9	6.00	6.2	0.39	3.9	6.50	6.2	0.39	3.9
13	108	153	10	100	152	158	10	100	165	158	10	100
¾	4.62	6.2	0.50	3.9	7.00	6.2	0.50	3.9	7.50	6.2	0.50	3.9
19	117	158	13	100	178	158	13	100	190	158	13	100
1	5.00	7.6	0.69	4.9	8.00	7.6	0.69	4.9	8.50	7.6	0.69	4.9
25	127	192	18	125	203	192	18	125	216	192	18	125
1¼	5.50	8.9	0.91	6.3	8.50	8.9	0.91	6.3	9.00	5.0	0.91	6.3
32	140	227	23	160	216	227	23	160	229	127	23	160
1½	6.50	9.4	1.12	6.3	9.00	9.4	1.12	6.3	9.50	9.4	1.12	6.3
38	165	240	29	160	229	240	29	160	241	240	29	160
2	8.00	11.0	1.38	7.1	10.50	11.0	1.38	7.1	11.50	11.0	1.38	7.1
50	203	279	35	180	267	279	35	180	292	279	35	180

SIZE	ASME 800															
	Bolted Bonnet						Welded Bonnet									
	Standard Bore			Full Bore			Standard Bore			Full Bore						
in	A	C	D	E	A	C	D	E	A	C	D	E	A	C	D	E
mm	WE				WE				WE				WE			
¼	3.11	6.1	0.26	3.9	-	-	-	-	3.11	6.1	0.26	3.9	-	-	-	-
6	79	154	7	100	-	-	-	-	79	154	7	100	-	-	-	-
¾	3.11	6.1	0.39	3.9	-	-	-	-	3.11	6.1	0.39	3.9	-	-	-	-
10	79	154	10	100	-	-	-	-	79	154	10	100	-	-	-	-
½	3.11	6.2	0.39	3.9	3.62	6.2	0.50	6.3	3.11	6.1	0.39	3.9	3.62	6.2	0.50	3.9
13	79	158	10	100	92	158	13	160	79	154	10	100	92	158	13	100
¾	3.62	6.2	0.50	3.9	4.37	7.6	0.69	4.9	3.62	6.2	0.50	3.9	4.37	7.6	0.69	4.9
19	92	158	13	100	111	192	18	125	92	158	13	100	111	192	18	125
1	4.37	7.6	0.69	4.9	4.72	8.9	0.91	6.3	4.37	7.6	0.69	4.9	4.72	8.9	0.91	6.3
25	111	192	18	125	120	227	23	160	111	192	18	125	120	227	23	160
1¼	4.72	8.9	0.91	6.3	5.98	9.4	1.12	6.3	4.72	8.9	0.91	6.3	5.98	9.4	1.12	6.3
32	120	227	23	160	152	240	29	160	120	227	23	160	152	240	29	160
1½	5.98	9.4	1.12	6.3	6.77	11.0	1.40	7.1	5.98	9.4	1.12	6.3	6.77	11.0	1.42	7.1
38	152	240	29	160	172	279	36	180	152	240	29	160	172	279	36	180
2	6.77	11.0	1.38	7.1	8.66	12.8	1.85	7.9	6.77	11.0	1.38	7.1	8.66	12.8	1.85	7.9
50	172	279	35	180	220	325	47	200	172	279	35	180	220	325	47	200

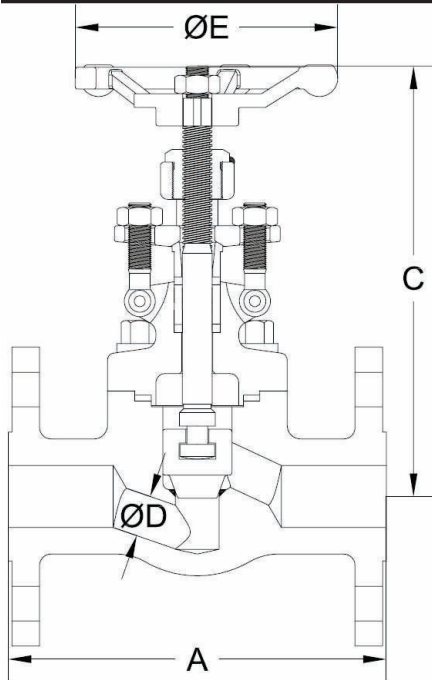

Bolted Bonnet Flanged Ends Design

**ADDITIONAL MATERIALS
AND CLASSES AVAILABLE
UPON REQUEST.**

WE = Socket Weld /
Threaded ends
FE = Flanged Ends
C = Center to top open

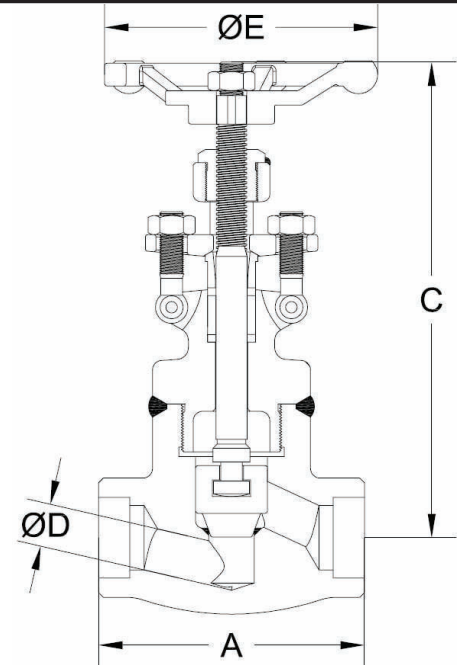

Welded Bonnet Socket Weld Ends Design

GLOBE VALVE DIMENSIONS (CLASS 1500—2680).

SIZE	ASME 1500 & 1690																
	Bolted Bonnet									Welded Bonnet							
	Standard Bore						Full Bore			Standard Bore				Full Bore			
	in	A		C	D	E	A	C	D	E	A	C	D	E	A	C	D
mm	FE	WE	WE														
¼	-	3.11	6.9	0.26	3.9	-	-	-	-	3.11	6.2	0.39	3.9	-	-	-	-
6	-	79	175	7	100	-	-	-	-	79	158	10	100	-	-	-	-
¾	-	3.62	7.0	0.39	4.9	-	-	-	-	3.62	6.2	0.50	3.9	-	-	-	-
10	-	92	178	10	125	-	-	-	-	92	158	13	100	-	-	-	-
½	8.50	3.62	7.4	0.39	4.9	4.37	7.4	0.50	4.9	4.37	7.4	0.39	4.9	4.37	7.4	0.50	4.9
13	216	92	187	10	125	111	187	13	125	111	187	10	125	111	187	13	125
¾	9.00	4.37	7.4	0.50	4.9	4.72	8.9	0.69	6.3	4.37	7.4	0.50	4.9	4.72	8.9	0.69	6.3
19	229	111	187	13	125	120	227	18	160	111	187	13	125	120	227	18	160
1	10.00	4.72	8.9	0.69	6.3	5.98	9.5	0.91	6.3	4.72	8.9	0.69	6.3	5.98	9.5	0.91	6.3
25	254	120	227	18	160	152	242	23	160	120	227	18	160	152	242	23	160
1¼	11.00	5.98	9.5	0.91	6.3	6.77	10.9	1.12	7.1	5.98	9.5	0.91	6.3	6.77	10.9	1.12	7.1
32	279	152	242	23	160	172	278	29	180	152	242	23	160	172	278	29	180
1½	12.00	6.77	10.9	1.12	7.1	8.66	12.8	1.38	7.9	6.77	10.9	1.12	7.1	8.66	12.8	1.38	7.9
38	305	172	278	29	180	220	325	35	200	172	278	29	180	220	325	35	200
2	14.50	8.66	12.8	1.38	7.9	9.84	14.0	1.85	7.9	8.66	12.8	1.38	7.9	9.84	14.0	1.85	7.9
50	368	220	325	35	200	250	355	47	200	220	325	35	200	250	355	47	200

SIZE	ASME 2500 & 2680								
	Bolted Bonnet					Welded Bonnet			
	Standard Bore					Standard Bore			
	in	A	C	D	E	A	C	D	E
mm	WE	WE							
½	5.91	11.5	0.43	6.3	5.91	9.8	0.55	6.3	
13	150	293	11	160	150	249	14	160	
¾	5.91	11.5	0.43	6.3	5.91	9.8	0.55	6.3	
19	150	293	11	160	150	249	14	160	
1	6.69	13.5	0.55	7.9	6.69	11.5	0.75	7.9	
25	170	344	14	200	170	292	19	200	
1¼	7.87	15.1	0.63	9.8	7.87	12.9	0.98	9.8	
32	200	383	16	250	200	327	25	250	
1½	7.87	15.1	0.98	9.8	7.87	12.9	1.10	9.8	
38	200	383	25	250	200	327	28	250	
2	9.84	17.4	1.10	11.8	9.84	15.0	1.38	11.8	
50	250	442	28	300	250	381	35	300	

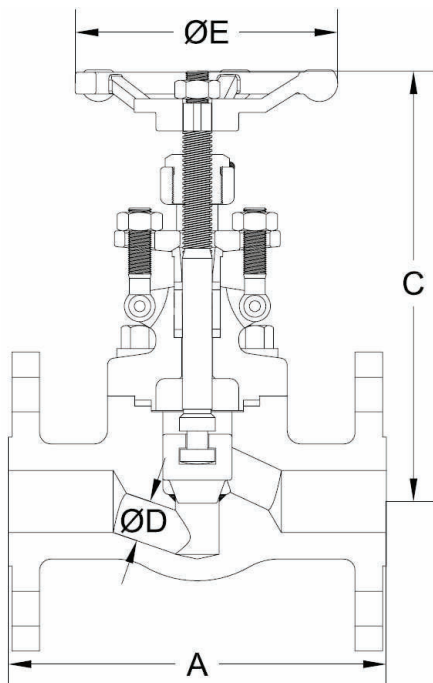

Bolted Bonnet Flanged Ends Design

**ADDITIONAL
MATERIALS AND
CLASSES AVAILABLE
UPON
REQUEST.**

WE = Socket Weld /
Threaded ends
FE = Flanged Ends
C = Center to top open

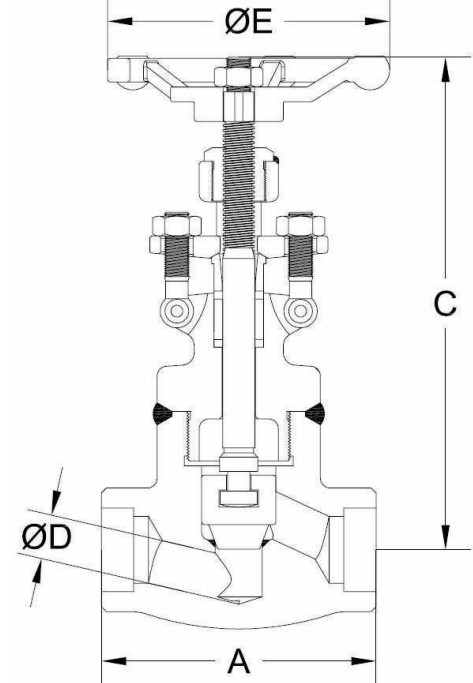

Welded Bonnet Socket Weld Ends Design



API 602 GLOBE VALVES
 FORGED CARBON , STAINLESS STEEL OR ALLOY STEEL
 ¼” TO 2” (6 TO 50 mm)
 ASME CLASSES 150 TO 2680

SIZE	ASME 150			ASME 300			ASME 600			ASME 800														
	Bolted Bonnet			Bolted Bonnet			Bolted Bonnet			Bolted Bonnet						Welded Bonnet								
	Standard Bore			Standard Bore			Standard Bore			Standard Bore			Full Bore			Standard Bore			Full Bore					
in	WT	LB	C _v	WT	LB	C _v	WT	LB	C _v	WT	LB	C _v	WT	LB	C _v	WT	LB	C _v	WT	LB	C _v	WT	LB	C _v
mm	FE	KG		FE	KG		FE	KG		WE	KG		WE	KG		WE	KG		WE	KG		WE	KG	
¼	-	-	-	-	-	-	-	-	4.6	0.7	-	-	4.4	0.7	-	-	-	-						
6	-	-	-	-	-	-	-	-	2.1	-	-	-	2.0	-	-	-	-	-						
¾	-	-	-	-	-	-	-	-	4.6	1.5	-	-	4.4	1.5	-	-	-	-						
10	-	-	-	-	-	-	-	-	2.1	-	-	-	2.0	-	-	-	-	-						
½	9.9	1.5	10.6	1.5	12.3	1.5	4.4	1.5	4.9	2.6	4.2	1.5	4.6	2.6	-	-	-	-						
13	4.5	-	4.8	-	5.6	-	2.0	-	2.2	-	1.9	-	2.1	-	-	-	-	-						
¾	15.2	2.7	17.0	2.7	17.2	2.7	4.9	2.7	8.4	4.9	4.6	2.7	8.2	4.9	-	-	-	-						
19	6.9	-	7.7	-	7.8	-	2.2	-	3.8	-	2.1	-	3.7	-	-	-	-	-						
1	21.6	5.1	24.3	5.1	27.6	5.1	5.5	5.1	12.1	8.9	8.2	5.1	11.9	8.9	-	-	-	-						
25	9.8	-	11.0	-	12.5	-	2.5	-	5.5	-	3.7	-	5.4	-	-	-	-	-						
1¼	29.8	9.1	37.0	9.1	37.5	9.1	12.1	9.1	15.4	13.7	11.9	9.1	15.2	13.7	-	-	-	-						
32	13.5	-	16.8	-	17.0	-	5.5	-	7.0	-	5.4	-	6.9	-	-	-	-	-						
1½	43.0	14.0	46.5	14.0	51.8	14.0	15.4	14.0	25.4	21.9	15.2	14.0	25.1	21.9	-	-	-	-						
38	19.5	-	21.2	-	23.5	-	7.0	-	11.5	-	6.9	-	11.4	-	-	-	-	-						
2	61.7	22.4	68.0	22.4	71.9	22.4	25.4	22.4	26.5	40	25.1	22.4	26.2	40	-	-	-	-						
50	28.0	-	31.0	-	32.6	-	11.5	-	12.0	-	11.4	-	11.9	-	-	-	-	-						

SIZE	ASME 1500 & 1687												ASME 2500 & 2680												
	Bolted Bonnet						Welded Bonnet						Bolted Bonnet			Welded Bonnet									
	Standard Bore			Full Bore			Standard Bore			Full Bore			Standard Bore			Standard Bore									
in	WT	LB	WT	LB	C _v	WT	LB	WT	LB	C _v	WT	LB	WT	LB	C _v	WT	LB	WT	LB	C _v	WT	LB	WT	LB	C _v
mm	FE	KG	WE	KG		WE	KG	WE	KG		WE	KG	WE	KG		WE	KG	WE	KG		WE	KG	WE	KG	
¼	-	-	6.6	-	0.7	-	-	6.2	-	0.7	-	-	-	-	-	-	-	-	-	-	-	-	-	-	
6	-	-	3.0	-	-	-	-	2.8	-	-	-	-	-	-	-	-	-	-	-	-	-	-	-	-	
¾	-	-	7.7	-	1.5	-	-	6.6	-	1.5	-	-	-	-	-	-	-	-	-	-	-	-	-	-	
10	-	-	3.5	-	-	-	-	3.0	-	-	-	-	-	-	-	-	-	-	-	-	-	-	-	-	
½	24.3	-	7.7	-	1.5	8.8	-	7.3	-	1.5	8.6	-	1.5	23.8	-	1.8	-	16.1	-	3.0	-	-	-	-	
13	11.0	-	3.5	-	-	4.0	-	3.3	-	-	3.9	-	-	10.8	-	-	-	7.3	-	-	-	-	-	-	
¾	29.1	-	8.8	-	2.7	13.9	-	8.4	-	2.7	13.7	-	2.7	24.3	-	1.9	-	18.7	-	3.1	-	-	-	-	
19	13.2	-	4.0	-	-	6.3	-	3.8	-	-	6.2	-	-	11.0	-	-	-	8.5	-	-	-	-	-	-	
1	38.4	-	13.9	-	5.1	17.6	-	13.4	-	5.1	17.4	-	5.1	26.8	-	3.2	-	27.6	-	6.0	-	-	-	-	
25	17.4	-	6.3	-	-	8.0	-	6.1	-	-	7.9	-	-	12.1	-	-	-	12.5	-	-	-	-	-	-	
1¼	41.9	-	17.6	-	9.1	27.6	-	17.2	-	9.1	27.3	-	9.1	47.8	-	4.3	-	45.6	-	10.5	-	-	-	-	
32	19.0	-	8.0	-	-	12.5	-	7.8	-	-	12.4	-	-	21.7	-	-	-	20.7	-	-	-	-	-	-	
1½	54.0	-	27.6	-	14.0	43.0	-	27.1	-	14.0	42.8	-	14.0	48.5	-	10.7	-	46.3	-	13.5	-	-	-	-	
38	24.5	-	12.5	-	-	19.5	-	12.3	-	-	19.4	-	-	22.0	-	-	-	21.0	-	-	-	-	-	-	
2	85.5	-	43.0	-	22.4	44.1	-	42.5	-	22.4	43.9	-	22.4	81.6	-	14.2	-	79.4	-	22.4	-	-	-	-	
50	38.8	-	19.5	-	-	20.0	-	19.3	-	-	19.9	-	-	37.0	-	-	-	36.0	-	-	-	-	-	-	

FE = Flanged Ends
WE = Socket Weld / Threaded Ends

WT = Weight
C_v = Flow Coefficient

STANDARD MATERIALS (Other materials available)

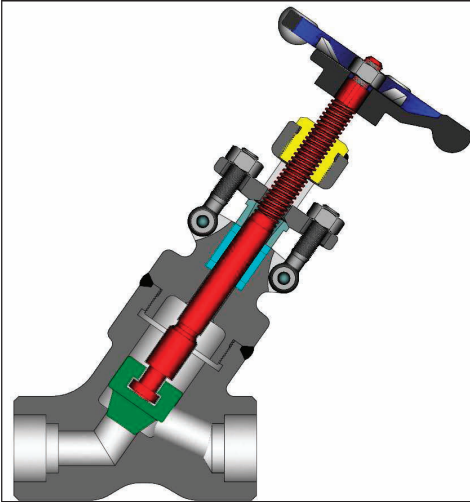

PART	MATERIALS			
Body	A105 + Stellite 6 Faced	A182 F11 + Stellite 6 Faced	A182 F22 + Stellite 6 Faced	A182 F316 (1)
Bonnet	A105	A182 F11	A182 F22	A182 F316
Disc	SST 420			A182 F316
Stem	A182 F6a			A182 F316
Gland Flange	A105			A182 F316
Eye Bolt	A193 Gr. B7	A193 Gr. B16		A193 Gr. B8M
Eye Bolt Nut	A194 Gr. 2H	A194 Gr. 7		A194 Gr. 8M
Gland	SST 420			Series 300 SST
Packing	Graphite			PTFE
Hand Wheel	Malleable Iron or Steel			
Hand Wheel Nut	Malleable Iron or Steel			
Identification Plate	Series 300 SST			

Class	Bore	Fig. No.
800	Standard	GY08
	Full	GYL8
1500	Standard	GY15
	Full	GYL5
1680	Standard	GY16
2500	Standard	GY25
2690	Standard	GY26

(1) Threaded and weld end valve bodies A182 F316L

NOTE: See page 43 for flow, safety and maintenance information.

Design Specifications

Item	Applicable Specification
Wall thickness	API 602
Pressure - temperature ratings	ASME B16.34
General valve design	API 602 & B16.34
End to End dimensions	ASME B16.10
Flange design	ASME B16.5
Thread design	ASME B1.20.1
Butt Weld design	ASME B16.25
Socket Weld design	ASME B16.11
Materials	ASTM

DESIGN FEATURES:

- **Standard trim** is stellite faced seat integral to the body, 13% chrome disc, and 13% chrome stem (API trim 8). Other trims available on request.
- **Wall thickness** per heavy wall API 602 requirements.
- **Seat faces** lapped for smooth finish and superior sealing.
- **Swivel disc** for optimal seating and longer seat life are non-rotating.
- **Stems** of hand wheel operated design are rotating / rising design.
- **Each valve** is shell, seat and backseat pressure tested per industry standard API 598.
- **Gland** is two piece gland / gland flange design for optimal alignment and uniform packing compression.
- **End Flanges** have the following raised faces per ASME B16.5:
Classes 150-300: 1/16” (2mm)
Classes 600: 1/4” (7mm)
- **Weld ends** are available per ASME B16.25/B16.11 or per customer’s specification.
- **Other** available options as follows:
-Alternate valve materials such as chrome and stainless steel alloys
-Alternate trim materials.
-NACE service.
-Special cleaning for applications such as oxygen or chlorine.
-Other options available as specified.

Y-PATTERN GLOBE VALVE DIMENSIONS (CLASS 800—2680).

SIZE	ASME 800											
	Bolted Bonnet						Welded Bonnet					
	Standard Bore						Standard Bore					
in	A	C	D	E	A	C	D	E	A	C	D	E
mm	WE				WE							
½	4.17	6.7	0.39	3.9	4.17	6.5	0.39	3.9	4.17	6.5	0.39	3.9
13	106	170	10	100	106	166	10	100	106	166	10	100
¾	4.17	6.7	0.50	3.9	4.17	6.5	0.50	3.9	4.17	6.5	0.50	3.9
19	106	170	13	100	106	166	13	100	106	166	13	100
1	4.72	8.0	0.69	4.9	4.72	7.8	0.69	4.9	4.72	7.8	0.69	4.9
25	120	202	18	125	120	197	18	125	120	197	18	125
1¼	5.98	9.8	0.91	6.3	5.98	9.6	0.91	6.3	5.98	9.6	0.91	6.3
32	152	249	23	160	152	243	23	160	152	243	23	160
1½	5.98	9.8	1.12	6.3	5.98	9.6	1.12	6.3	5.98	9.6	1.12	6.3
38	152	249	29	160	152	243	29	160	152	243	29	160
2	7.09	11.1	1.38	7.1	7.09	10.7	1.38	7.1	7.09	10.7	1.38	7.1
50	180	281	35	180	180	272	35	180	180	272	35	180

SIZE	ASME 1500 & 1690								ASME 2500 & 2680			
	Bolted Bonnet				Welded Bonnet				Welded Bonnet			
	Standard Bore				Standard Bore				Standard Bore			
in	A	C	D	E	A	C	D	E	A	C	D	E
mm	WE				WE							
½	4.72	7.9	0.39	4.9	4.72	7.6	0.39	4.9	5.98	9.6	0.43	6.3
13	120	200	10	125	120	192	10	125	152	243	11	160
¾	4.72	7.9	0.50	4.9	4.72	7.6	0.50	4.9	5.98	9.6	0.55	6.3
19	120	200	13	125	120	192	13	125	152	243	14	160
1	5.98	9.8	0.69	6.3	5.98	9.4	0.69	6.3	7.09	11.4	0.75	7.9
25	152	250	18	160	152	240	18	160	180	290	19	200
1¼	5.98	9.8	0.91	6.3	5.98	9.4	0.91	6.3	7.87	13.2	0.98	9.8
32	152	250	23	160	152	240	23	160	200	335	25	250
1½	7.09	11.1	1.12	7.1	7.09	10.7	1.12	7.1	7.87	13.2	1.10	9.8
38	180	283	29	180	180	273	29	180	200	335	28	250
2	7.87	12.8	1.38	7.9	7.87	12.4	1.38	7.9	9.06	15.4	1.38	11.8
50	200	324	35	200	200	316	35	200	230	390	35	300

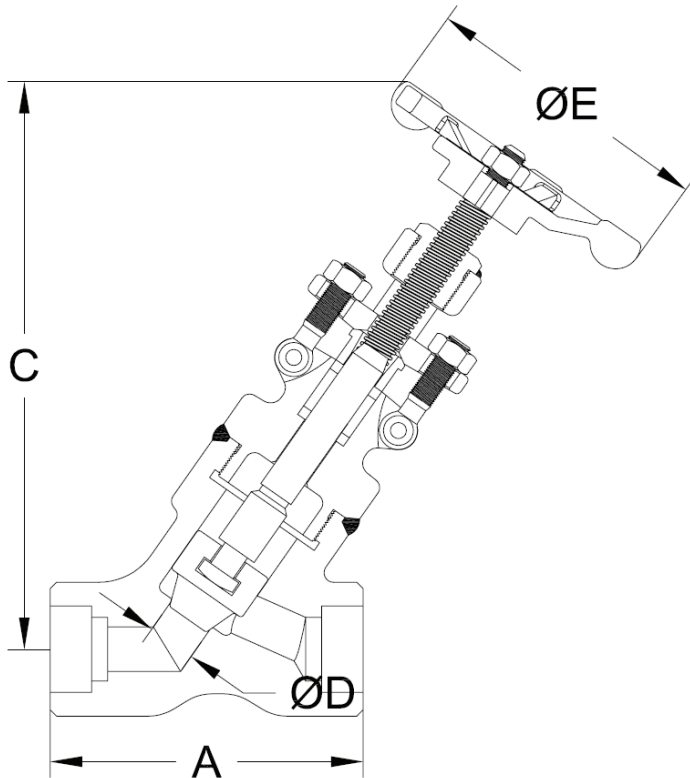

ADDITIONAL MATERIALS AND CLASSES AVAILABLE UPON REQUEST.

WE = Socket Weld / Threaded Ends

C = Center to top open



API 602 Y-PATTERN GLOBE VALVES
 FORGED CARBON , STAINLESS STEEL OR ALLOY STEEL
 ¼” TO 2” (6 TO 50 mm)
 ASME CLASSES 800 TO 2680

SIZE	ASME 800						ASME 1500 & 1687						ASME 2500 & 2680		
	Bolted Bonnet			Welded Bonnet			Bolted Bonnet			Welded Bonnet			Welded Bonnet		
	Standard Bore			Standard Bore			Standard Bore			Standard Bore			Standard Bore		
in	WT	LB	C _v	WT	LB	C _v	WT	LB	C _v	WT	LB	C _v	WT	LB	C _v
mm	WE	KG		WE	KG		WE	KG		WE	KG		WE	KG	
½	4.4		3.3	3.3		3.3	9.3		3.3	7.7		3.3	9.9		4.0
13	2.0			1.5			4.2			3.5			4.5		
¾	4.9		5.9	4.4		5.9	9.3		5.9	7.7		5.9	15.7		6.8
19	2.2			2.0			4.2			3.5			7.1		
1	9.3		11.2	8.4		11.2	12.1		11.2	11.0		11.2	24.3		13.3
25	4.2			3.8			5.5			5.0			11.0		
1¼	12.1		20.0	11.0		20.0	20.7		20.0	19.8		20.0	37.7		23.1
32	5.5			5.0			9.4			9.0			17.1		
1½	20.7		30	19.8		30	28.7		30	23.1		30	37.7		30
38	9.4			9.0			13.0			10.5			17.1		
2	28.7		49	28.7		49	36.4		49	32.0		49	55.1		49
50	13.0			13.0			16.5			14.5			25.0		

FE = Flanged Ends
WE = Socket Weld / Threaded Ends

WT = Weight
C_v = Flow Coefficient

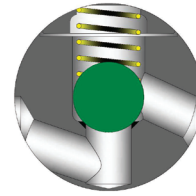
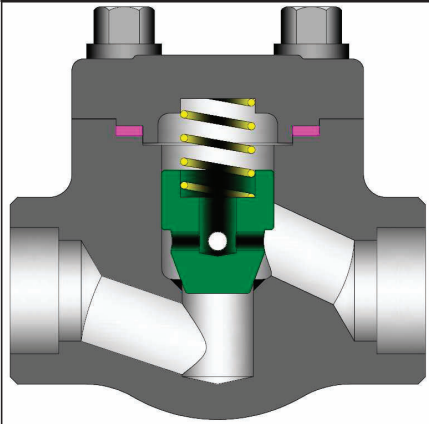

Ball Check

STANDARD MATERIALS (Other materials available)

Class	Bore	Fig. No.	
		Piston	Ball
150	Standard	PC01	BC01
	Full	PCL1	BCL1
300	Standard	PC03	BC03
	Full	PCL3	BCL3
600	Standard	PC06	BC06
	Full	PCL6	BCL6
800	Standard	PC08	BC08
	Full	PCL8	BCL8
1500	Standard	PC15	BC15
	Full	PCL5	BCL5
1680	Standard	PC16	BC16
2500	Standard	PC25	BC25
2690	Standard	PC26	BC26

PART	MATERIALS			
Body	A105 + Stellite 6 Faced	A182 F11 + Stellite 6 Faced	A182 F22 + Stellite 6 Faced	A182 F316 (1)
Cap	A105	A182 F11	A182 F22	A182 F316
Disc/Ball	A276 T420			A276 T316
Gasket (2)	Spiral Wound SST with Graphite			Spiral Wound SST with PTFE
Spring	Inconel 625			
Body / Cap Bolting (2)	A193 Gr. B7	A193 Gr. B16		A193 Gr. B8M
Identification Plate	Series 300 SST			

DESIGN FEATURES:

- **Standard trim** is stellite faced seat integral to the body and 13% chrome disc/ball (API trim 8). Other trims available on request.
- **Seat faces** lapped for smooth finish and superior sealing.
- **Wall thickness** per heavy wall API 602 requirements.
- **Each valve** is shell and seat pressure tested per industry standard API 598.
- **Check valve** are suitable for service in horizontal line with cap vertical.
- **End Flanges** have the following raised faces per ASME B16.5:
Classes 150-300: 1/16" (2mm).
Classes 600: 1/4" (7mm).
- **Other available options** as follows:
-Alternate valve materials such as chrome and stainless steel alloys.
-Alternate trim materials.
-NACE service.
-Special cleaning for applications such as oxygen or chlorine.
-Other options available as specified.

- (1) Threaded and weld end valve bodies A182 F316L
- (2) Welded bonnets also available.

NOTE: See page 43 for flow, safety and maintenance information.

Design Specifications

Item	Applicable Specification
Wall thickness	API 602
Pressure - temperature ratings	ASME B16.34
General valve design	API 602 & B16.34
End to End dimensions	ASME B16.10
Flange design	ASME B16.5
Thread design	ASME B1.20.1
Butt Weld design	ASME B16.25
Socket Weld design	ASME B16.11
Materials	ASTM

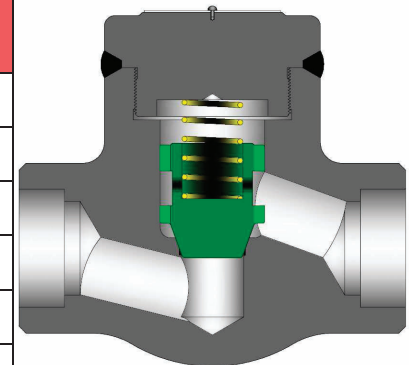

Welded Bonnet Design

PISTON CHECK VALVE DIMENSIONS (CLASS 150—800).

SIZE	ASME 150			ASME 300			ASME 600		
	Bolted Bonnet			Bolted Bonnet			Bolted Bonnet		
	Standard Bore			Standard Bore			Standard Bore		
in	A	C	D	A	C	D	A	C	D
mm	FE			FE			FE		
½	4.25	2.2	0.39	6.00	2.2	0.39	6.50	2.2	0.39
13	108	55	10	152	55	10	165	55	10
¾	4.62	2.2	0.50	7.00	2.2	0.50	7.50	2.2	0.50
19	117	55	13	178	55	13	190	55	13
1	5.00	2.8	0.69	8.00	2.8	0.69	8.50	2.8	0.69
25	127	72	18	203	72	18	216	72	18
1¼	5.50	3.2	0.91	8.50	3.2	0.91	9.00	3.2	0.91
32	140	81	23	216	81	23	229	81	23
1½	6.50	3.6	1.12	9.00	3.7	1.12	9.50	3.7	1.12
38	165	91	29	229	94	29	241	94	29
2	8.00	4.4	1.26	10.50	4.4	1.38	11.50	4.4	1.38
50	203	112	32	267	112	35	292	112	35

SIZE	ASME 800											
	Bolted Bonnet						Welded Bonnet					
	Standard Bore			Full Bore			Standard Bore			Full Bore		
in	A	C	D	A	C	D	A	C	D	A	C	D
mm	WE			WE			WE			WE		
¼	3.11	2.2	0.26	-	-	-	3.11	2.2	0.26	-	-	-
6	79	55	7	-	-	-	79	55	7	-	-	-
¾	3.11	2.2	0.39	-	-	-	3.11	2.2	0.39	-	-	-
10	79	55	10	-	-	-	79	55	10	-	-	-
½	3.11	2.2	0.39	3.62	2.2	0.50	3.11	2.2	0.39	3.62	2.2	0.50
13	79	55	10	92	55	13	79	55	10	92	55	13
¾	3.62	2.2	0.50	4.37	3.0	0.69	3.62	2.2	0.50	4.37	3.0	0.69
19	92	55	13	111	72	18	92	55	13	111	72	18
1	4.37	3.0	0.69	4.72	3.2	0.91	4.37	3.0	0.69	4.72	3.2	0.91
25	111	72	18	120	81	23	111	72	18	120	81	23
1¼	4.72	3.2	0.91	5.98	3.7	1.12	4.72	3.2	0.91	5.98	3.7	1.12
32	120	81	23	152	94	29	120	81	23	152	94	29
1½	5.98	3.7	1.12	6.77	4.4	1.40	5.98	3.7	1.12	6.77	4.4	1.42
38	152	94	29	172	112	36	152	94	29	172	112	36
2	6.77	4.4	1.38	8.66	5.2	1.85	6.77	4.4	1.38	8.66	5.2	1.85
50	172	112	35	220	132	47	172	112	35	220	132	47

ADDITIONAL MATERIALS AND CLASSES AVAILABLE UPON REQUEST.

WE = Socket Weld / Threaded Ends
FE = Flanged Ends
C = Center to top

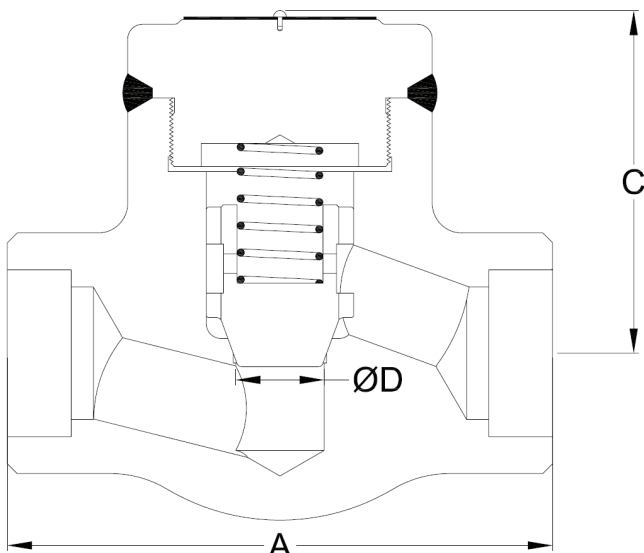

Welded Bonnet Socket Weld Ends Design

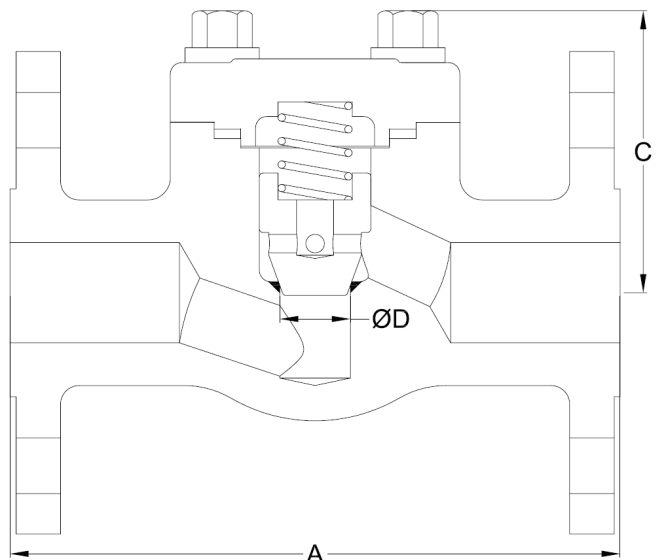

Bolted Bonnet Flanged Ends Design

PISTON CHECK VALVE DIMENSIONS (CLASS 1500—2680).

SIZE	ASME 1500 & 1690												
	Bolted Bonnet						Welded Bonnet						
	Standard Bore				Full Bore		Standard Bore			Full Bore			
	A		C	D	A	C	D	A		C	D	A	
FE	WE	WE						WE	WE			WE	WE
¼	-	3.11	2.9	0.26	-	-	-	3.11	2.9	0.39	-	-	-
6	-	79	73	7	-	-	-	79	73	10	-	-	-
¾	-	3.11	2.9	0.39	-	-	-	3.11	2.9	0.50	-	-	-
10	-	79	73	10	-	-	-	79	73	13	-	-	-
½	8.50	3.62	2.9	0.39	4.37	2.9	0.50	3.62	2.9	0.39	4.37	2.9	0.50
13	216	92	73	10	111	73	13	92	73	10	111	73	13
¾	9.00	4.37	2.9	0.50	4.72	3.3	0.69	4.37	2.9	0.51	4.72	3.3	0.69
19	229	111	73	13	120	84	18	111	73	13	120	84	18
1	10.00	4.72	3.3	0.69	5.98	3.8	0.91	4.72	3.3	0.69	5.98	3.8	0.91
25	254	120	84	18	152	97	23	120	84	18	152	97	23
1¼	11.00	5.98	3.8	0.91	6.77	4.5	1.12	5.98	3.8	0.91	6.77	4.5	1.12
32	279	152	97	23	172	115	29	152	97	23	172	115	29
1½	12.00	6.77	4.5	1.12	8.66	5.2	1.38	6.77	4.5	1.12	8.66	5.2	1.38
38	305	172	115	29	220	132	35	172	115	29	220	132	35
2	14.50	8.66	5.2	1.38	9.84	5.2	1.85	8.66	5.2	1.38	10.24	5.2	1.85
50	368	220	132	35	250	132	47	220	132	35	260	132	47

SIZE	ASME 2500 & 2680							
	Bolted Bonnet			Welded Bonnet				
	Standard Bore			Standard Bore				
	A		C	D	A		C	D
FE	WE	WE			WE			
½	-	5.91	4.0	0.43	-	5.91	5.3	0.55
13	-	150	102	11	-	150	135	14
¾	-	5.91	4.0	0.43	-	5.91	5.3	0.55
19	-	150	102	11	-	150	135	14
1	-	6.69	4.2	0.55	-	6.69	5.7	0.75
25	-	170	107	14	-	170	146	19
1¼	-	7.87	5.0	0.63	-	7.87	6.9	0.98
32	-	200	128	16	-	200	176	25
1½	-	7.87	5.0	0.98	-	7.87	6.9	1.10
38	-	200	128	25	-	200	176	28
2	-	9.84	5.6	1.10	-	9.84	7.7	1.38
50	-	250	143	28	-	250	196	35

**ADDITIONAL MATERIALS
AND CLASSES AVAILABLE
UPON REQUEST.**

WE = Socket Weld / Threaded Ends
FE = Flanged Ends
C = Center to top open

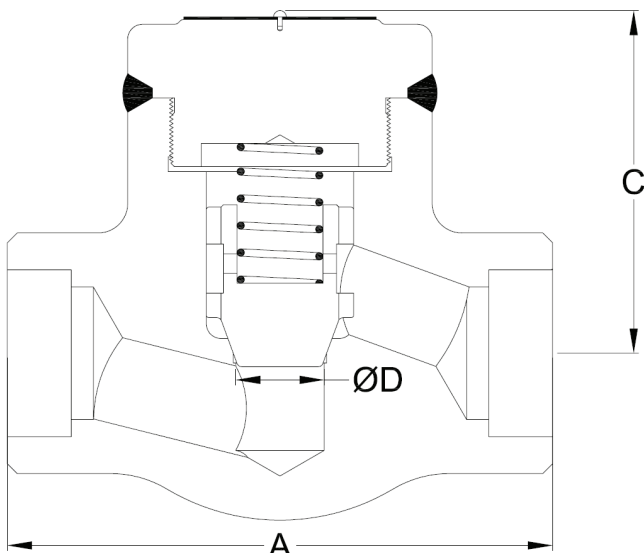

Welded Bonnet Socket Weld Ends Design

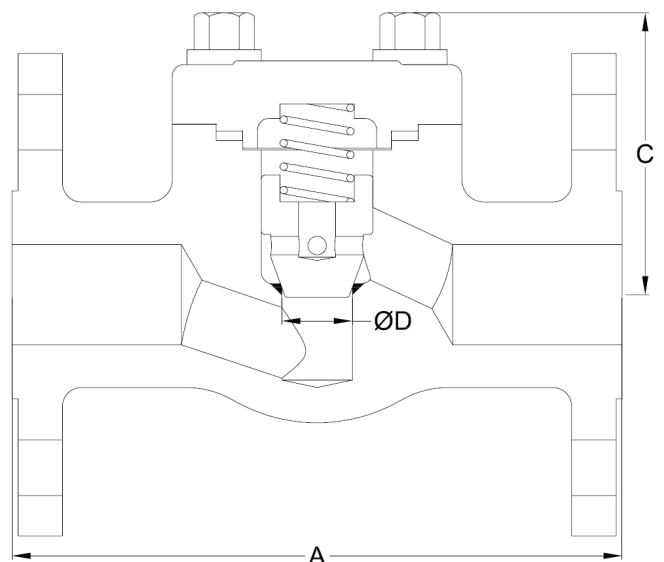

Bolted Bonnet Flanged Ends Design



API 602 PISTON CHECK VALVES
 FORGED CARBON , STAINLESS STEEL OR ALLOY STEEL
 ¼" TO 2" (6 TO 50 mm)
 ASME CLASSES 150 TO 2680

SIZE	ASME 150			ASME 300			ASME 600			ASME 800														
	Bolted Bonnet			Bolted Bonnet			Bolted Bonnet			Bolted Bonnet						Welded Bonnet								
	Standard Bore			Standard Bore			Standard Bore			Standard Bore			Full Bore			Standard Bore			Full Bore					
in	WT	LB	C _v	WT	LB	C _v	WT	LB	C _v	WT	LB	C _v	WT	LB	C _v	WT	LB	C _v	WT	LB	C _v	WT	LB	C _v
mm	FE	KG		FE	KG		FE	KG		WE	KG		WE	KG		WE	KG		WE	KG		WE	KG	
¼	-	-	-	-	-	-	-	-	-	3.3	0.7	-	-	3.1	0.7	-	-	-	-	-	-			
6	-	-	-	-	-	-	-	-	-	1.5	-	-	-	1.4	-	-	-	-	-	-	-			
¾	-	-	-	-	-	-	-	-	-	3.3	1.5	-	-	3.1	1.5	-	-	-	-	-	-			
10	-	-	-	-	-	-	-	-	-	1.5	-	-	-	1.4	-	-	-	-	-	-	-			
½	7.5	1.5	-	8.2	1.5	-	7.5	1.5	-	3.1	1.5	-	4.2	2.6	-	3.1	1.5	-	4.2	2.6	-			
13	3.4	-	-	3.7	-	-	3.4	-	-	1.4	-	-	1.9	-	-	1.4	-	-	1.9	-	-			
¾	9.7	2.7	-	10.6	2.7	-	12.8	2.7	-	4.2	2.7	-	5.7	4.9	-	4.0	2.7	-	5.7	4.9	-			
19	4.4	-	-	4.8	-	-	5.8	-	-	1.9	-	-	2.6	-	-	1.8	-	-	2.6	-	-			
1	18.1	5.1	-	19.4	5.1	-	20.9	5.1	-	5.7	5.1	-	9.3	8.9	-	5.7	5.1	-	9.3	8.9	-			
25	8.2	-	-	8.8	-	-	9.5	-	-	2.6	-	-	4.2	-	-	2.6	-	-	4.2	-	-			
1¼	19.6	9.1	-	21.2	9.1	-	22.9	9.1	-	9.3	9.1	-	11.7	13.7	-	9.3	9.1	-	11.7	13.7	-			
32	8.9	-	-	9.6	-	-	10.4	-	-	4.2	-	-	5.3	-	-	4.2	-	-	5.3	-	-			
1½	26.5	14.0	-	30.2	14.0	-	34.4	14.0	-	11.7	14.0	-	19.8	21.9	-	11.7	14.0	-	19.8	21.9	-			
38	12.0	-	-	13.7	-	-	15.6	-	-	5.3	-	-	9.0	-	-	5.3	-	-	9.0	-	-			
2	31.5	22.4	-	39.2	22.4	-	54.0	22.4	-	19.8	22.4	-	34.4	40	-	19.8	22.4	-	34.4	40	-			
50	14.3	-	-	17.8	-	-	24.5	-	-	9.0	-	-	15.6	-	-	9.0	-	-	15.6	-	-			

SIZE	ASME 1500 & 1687												ASME 2500 & 2680										
	Bolted Bonnet						Welded Bonnet						Bolted Bonnet			Welded Bonnet							
	Standard Bore			Full Bore			Standard Bore			Full Bore			Standard Bore			Standard Bore							
in	WT	LB	WT	LB	C _v	WT	LB	C _v	WT	LB	C _v	WT	LB	C _v	WT	LB	C _v	WT	LB	C _v	WT	LB	C _v
mm	FE	KG	WE	KG		WE	KG		WE	KG		WE	KG		WE	KG		WE	KG		WE	KG	
¼	-	-	4.9	-	0.7	-	-	-	4.9	-	0.7	-	-	-	-	-	-	-	-	-	-	-	-
6	-	-	2.2	-	-	-	-	-	2.2	-	-	-	-	-	-	-	-	-	-	-	-	-	-
¾	-	-	4.9	-	1.5	-	-	-	4.9	-	1.5	-	-	-	-	-	-	-	-	-	-	-	-
10	-	-	2.2	-	-	-	-	-	2.2	-	-	-	-	-	-	-	-	-	-	-	-	-	-
½	20.7	5.3	-	5.3	1.5	-	6.4	1.5	-	5.3	1.5	-	6.4	1.5	-	17.6	1.8	-	15.4	3.0	-	-	-
13	9.4	-	-	2.4	-	-	2.9	-	-	2.4	-	-	2.9	-	-	8.0	-	-	7.0	-	-	-	-
¾	24.7	6.4	-	6.4	2.7	-	10.1	2.7	-	6.4	2.7	-	10.1	2.7	-	17.2	1.9	-	15.0	3.1	-	-	-
19	11.2	-	-	2.9	-	-	4.6	-	-	2.9	-	-	4.6	-	-	7.8	-	-	6.8	-	-	-	-
1	31.7	10.1	-	10.1	5.1	-	14.3	5.1	-	10.1	5.1	-	14.3	5.1	-	26.5	3.2	-	24.3	6.0	-	-	-
25	14.4	-	-	4.6	-	-	6.5	-	-	4.6	-	-	6.5	-	-	12.0	-	-	11.0	-	-	-	-
1¼	35.3	14.3	-	14.3	9.1	-	23.1	9.1	-	14.3	9.1	-	23.1	9.1	-	43.0	4.3	-	39.7	10.5	-	-	-
32	16.0	-	-	6.5	-	-	10.5	-	-	6.5	-	-	10.5	-	-	19.5	-	-	18.0	-	-	-	-
1½	47.4	23.1	-	23.1	14.0	-	34.4	14.0	-	23.1	14.0	-	34.4	14.0	-	42.5	10.7	-	39.0	13.5	-	-	-
38	21.5	-	-	10.5	-	-	15.6	-	-	10.5	-	-	15.6	-	-	19.3	-	-	17.7	-	-	-	-
2	61.7	34.2	-	34.2	22.4	-	37.5	22.4	-	34.2	22.4	-	37.5	22.4	-	59.5	14.2	-	63.9	22.4	-	-	-
50	28.0	-	-	15.5	-	-	17.0	-	-	15.5	-	-	17.0	-	-	27.0	-	-	29.0	-	-	-	-

FE = Flanged Ends
WE = Socket Weld / Threaded Ends

WT = Weight
C_v = Flow Coefficient

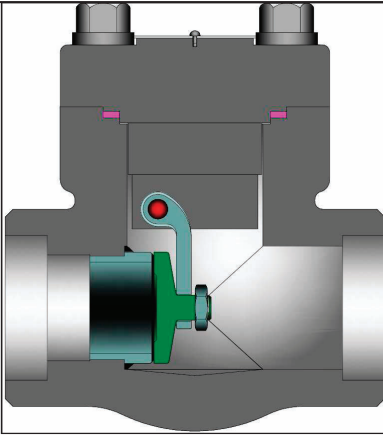

Class	Bore	Fig. No.
150	Standard	SW01
	Full	SWL1
300	Standard	SW03
	Full	SWL3
600	Standard	SW06
	Full	SWL6
800	Standard	SW08
	Full	SWL8
1500	Standard	SW15
	Full	SWL5
1680	Standard	SW16
2500	Standard	SW25
2690	Standard	SW26

DESIGN FEATURES:

- **Standard trim** is stellite faced seat rings and 13% chrome disc (API trim 8). Other trims available on request.
- **Seat faces** lapped for smooth finish and superior sealing.
- **Wall thickness** per heavy wall API 602 requirements.
- **Swivel disc** for improved seat alignment and longer life.
- **Each valve** is shell and seat pressure tested per industry standard API 598.
- **Check valve** are suitable for service in horizontal line with cap vertical or in a vertical line with flow upward.
- **Carrier Pin** is confined within the body wall and is not accessible from the exterior, thus no side body penetrations, eliminating a common leak path.
- **End Flanges** have the following raised faces per ASME B16.5:
Classes 150-300: 1/16" (2mm).
Classes 600: 1/4" (7mm).

STANDARD MATERIALS (Other materials available)

PART	MATERIALS			
Body	A105	A182 F11	A182 F22	A182 F316 (1)
Cap	A105	A182 F11	A182 F22	A182 F316
Disc	A276 T420			A276 T316
Seat Ring	SST 410 + Stellite 6 Faced			316 SST
Gasket (2)	Spiral Wound SST with Graphite			Spiral Wound SST with PTFE
Carrier	304 SST			316 SST
Carrier Pin	304 SST			316 SST
Disc Nut	A182 F304 or A194 Gr. 8			A182 F316 or A194 Gr. 8M
Body / Cap Bolting (2)	A193 Gr. B7	A193 Gr. B16		A193 Gr. B8M
Identification Plate	Series 300 SST			

- (1) Threaded and weld end valve bodies A182 F316L
- (2) Welded bonnets also available.

NOTE: See page 43 for flow, safety and maintenance information.

Design Specifications

Item	Applicable Specification
Wall thickness	API 602
Pressure - temperature ratings	ASME B16.34
General valve design	API 602 & B16.34
End to End dimensions	ASME B16.10
Flange design	ASME B16.5
Thread design	ASME B1.20.1
Butt Weld design	ASME B16.25
Socket Weld design	ASME B16.11
Materials	ASTM

- **Other** available options as follows:
-Alternate valve materials such as chrome and stainless steel alloys
-Alternate trim materials
-NACE service
-Special cleaning for applications such as oxygen or chlorine
-Other options available as specified

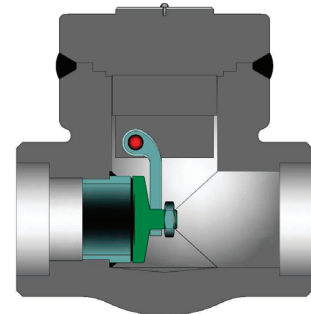

Welded Bonnet Design

SWING CHCK VALVE DIMENSIONS (CLASS 150—800).

SIZE	ASME 150			ASME 300			ASME 600		
	Bolted Bonnet			Bolted Bonnet			Bolted Bonnet		
	Standard Bore			Standard Bore			Standard Bore		
in	A	C	D	A	C	D	A	C	D
mm	FE			FE			FE		
½	4.25	2.2	0.39	6.00	2.2	0.39	6.50	2.2	0.39
13	108	55	10	152	55	10	165	55	10
¾	4.62	2.2	0.50	7.00	2.2	0.50	7.50	2.2	0.50
19	117	55	13	178	55	13	190	55	13
1	5.00	2.8	0.69	8.00	2.8	0.69	8.50	2.8	0.69
25	127	72	18	203	72	18	216	72	18
1¼	5.50	3.2	0.91	8.50	3.2	0.91	9.00	3.2	0.91
32	140	81	23	216	81	23	229	81	23
1½	6.50	3.6	1.12	9.00	3.7	1.12	9.50	3.7	1.12
38	165	91	29	229	94	29	241	94	29
2	8.00	4.4	1.26	10.50	4.4	1.38	11.50	4.4	1.38
50	203	112	32	267	112	35	292	112	35

SIZE	ASME 800											
	Bolted Bonnet						Welded Bonnet					
	Standard Bore			Full Bore			Standard Bore			Full Bore		
in	A	C	D	A	C	D	A	C	D	A	C	D
mm	WE			WE			WE			WE		
¼	3.11	2.2	0.26	-	-	-	3.11	2.2	0.26	-	-	-
6	79	55	7	-	-	-	79	55	7	-	-	-
¾	3.11	2.2	0.39	-	-	-	3.11	2.2	0.39	-	-	-
10	79	55	10	-	-	-	79	55	10	-	-	-
½	3.11	2.2	0.39	3.62	2.2	0.50	3.11	2.2	0.39	3.62	2.2	0.50
13	79	55	10	92	55	13	79	55	10	92	55	13
¾	3.62	2.2	0.50	4.37	3.0	0.69	3.62	2.2	0.50	4.37	3.0	0.69
19	92	55	13	111	72	18	92	55	13	111	72	18
1	4.37	3.0	0.69	4.72	3.2	0.91	4.37	3.0	0.69	4.72	3.2	0.91
25	111	72	18	120	81	23	111	72	18	120	81	23
1¼	4.72	3.2	0.91	4.72	3.7	1.12	4.72	3.2	0.91	4.72	3.7	1.12
32	120	81	23	120	94	29	120	81	23	120	94	29
1½	4.72	3.7	1.12	5.51	4.4	1.40	4.72	3.7	1.12	5.51	4.4	1.42
38	120	94	29	140	112	36	120	94	29	140	112	36
2	5.51	4.4	1.38	6.30	5.2	1.85	5.51	4.4	1.38	6.30	5.2	1.85
50	140	112	35	160	132	47	140	112	35	160	132	47

ADDITIONAL MATERIALS AND CLASSES AVAILABLE UPON REQUEST.

WE = Socket Weld / Threaded Ends
FE = Flanged Ends
C = Center to top

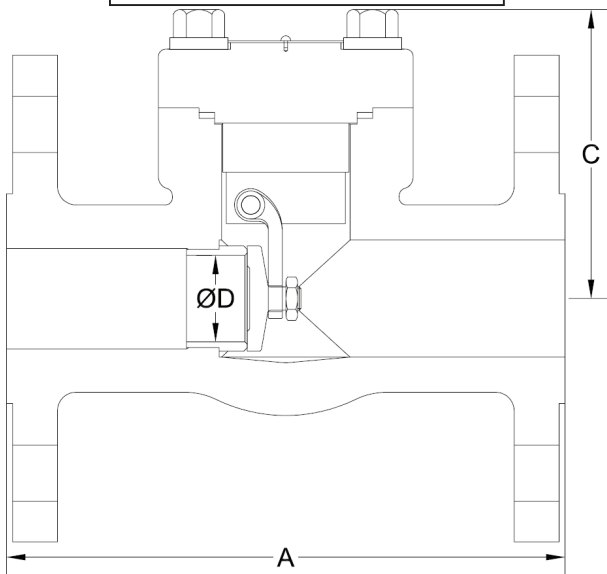

Bolted Bonnet Flanged Ends Design

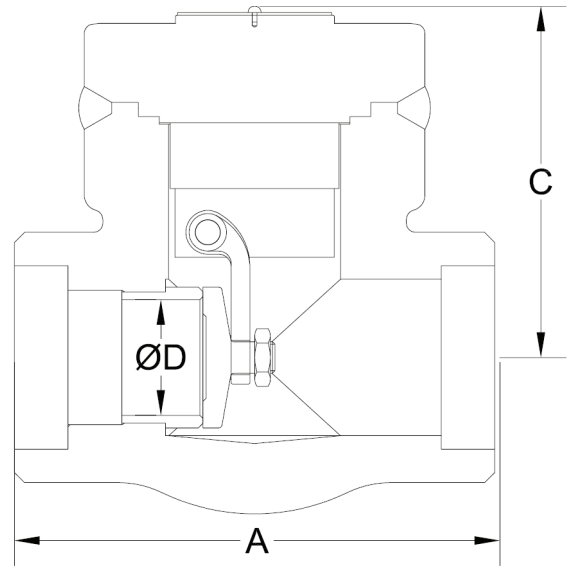

Welded Bonnet Socket Weld Ends Design

SWING CHECK VALVE DIMENSIONS (CLASS 1500—2680).

SIZE	ASME 1500 & 1690												
	Bolted Bonnet						Welded Bonnet						
	Standard Bore			Full Bore			Standard Bore			Full Bore			
	A		C	D	A		C	D	A		C	D	
in	FE	WE			in	FE			WE	in			FE
¼	-	3.11	2.9	0.26	-	-	-	3.11	2.9	0.39	-	-	-
6	-	79	73	7	-	-	-	79	65	10	-	-	-
¾	-	3.11	2.9	0.39	-	-	-	3.11	2.9	0.50	-	-	-
10	-	79	73	10	-	-	-	79	65	13	-	-	-
½	8.50	3.62	2.9	0.39	4.37	2.9	0.50	3.62	2.9	0.39	4.37	2.9	0.50
13	216	92	73	10	111	73	13	92	65	10	111	65	13
¾	9.00	4.37	2.9	0.50	4.72	3.3	0.69	4.37	2.9	0.51	4.72	3.3	0.69
19	229	111	73	13	120	84	18	111	65	13	120	77	18
1	10.00	4.72	3.3	0.69	4.72	3.8	0.91	4.72	3.3	0.69	4.72	3.8	0.91
25	254	120	84	18	120	97	23	120	77	18	120	89	23
1¼	11.00	4.72	3.8	0.91	5.51	4.5	1.12	4.72	3.8	0.91	5.51	4.5	1.12
32	279	120	97	23	140	115	29	120	89	23	140	103	29
1½	12.00	5.51	4.5	1.12	6.30	5.2	1.38	5.51	4.5	1.12	6.30	5.2	1.38
38	305	140	115	29	160	132	35	140	103	29	160	115	35
2	14.50	6.30	5.2	1.38	8.66	5.2	1.85	6.30	5.2	1.38	8.66	5.2	1.85
50	368	160	132	35	220	152	47	160	115	35	220	132	47

SIZE	ASME 2500 & 2680						
	Bolted Bonnet			Welded Bonnet			
	Standard Bore			Standard Bore			
	A		C	D	A		C
in	WE	in			WE		
½	5.91	3.4	0.55	5.91	3.4	0.55	
13	150	87	14	150	87	14	
¾	5.91	3.6	0.55	5.91	3.4	0.55	
19	150	92	14	150	87	14	
1	6.69	4.4	0.75	6.69	3.6	0.75	
25	170	113	19	170	92	19	
1¼	7.87	4.4	1.10	7.87	4.4	1.10	
32	200	113	28	200	113	28	
1½	7.87	5.2	1.10	7.87	4.4	1.10	
38	200	131	28	200	113	28	
2	9.84	5.9	1.50	9.84	5.2	1.50	
50	250	151	38	250	131	38	

**ADDITIONAL MATERIALS
AND CLASSES AVAILABLE
UPON REQUEST.**

WE = Socket Weld / Threaded Ends
FE = Flanged Ends
C = Center to top open

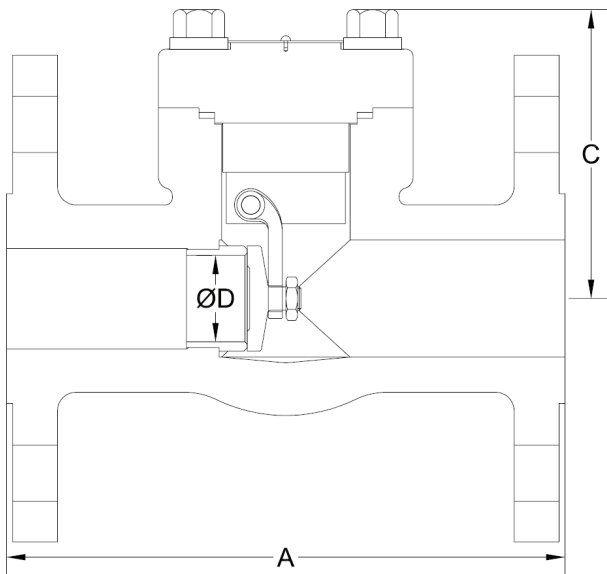

Bolted Bonnet Flanged Ends Design

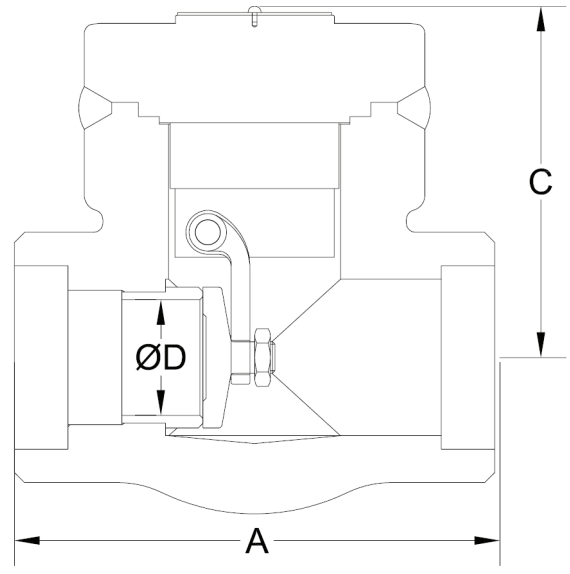

Welded Bonnet Socket Weld Ends Design



API 602 SWING CHECK VALVES
 FORGED CARBON , STAINLESS STEEL OR ALLOY STEEL
 ¼" TO 2" (6 TO 50 mm)
 ASME CLASSES 150 TO 2680

SIZE	ASME 150			ASME 300			ASME 600			ASME 800														
	Bolted Bonnet			Bolted Bonnet			Bolted Bonnet			Bolted Bonnet						Welded Bonnet								
	Standard Bore			Standard Bore			Standard Bore			Standard Bore			Full Bore			Standard Bore			Full Bore					
in	WT	LB	C _v	WT	LB	C _v	WT	LB	C _v	WT	LB	C _v	WT	LB	C _v	WT	LB	C _v	WT	LB	C _v	WT	LB	C _v
mm	FE	KG		FE	KG		FE	KG		WE	KG		WE	KG		WE	KG		WE	KG		WE	KG	
¼	-	-	-	-	-	-	-	-	-	2.9	0.7	-	-	2.9	0.7	-	-	-	-	-	-			
6	-	-	-	-	-	-	-	-	-	1.3	-	-	-	1.3	-	-	-	-	-	-	-			
¾	-	-	-	-	-	-	-	-	-	2.9	1.5	-	-	2.9	1.5	-	-	-	-	-	-			
10	-	-	-	-	-	-	-	-	-	1.3	-	-	-	1.3	-	-	-	-	-	-	-			
½	7.1	1.5	-	7.7	1.5	-	7.1	1.5	-	2.6	1.5	-	3.7	2.6	-	2.6	1.5	-	3.7	2.6	-			
13	3.2	-	-	3.5	-	-	3.2	-	-	1.2	-	-	1.7	-	-	1.2	-	-	1.7	-	-			
¾	9.3	2.7	-	10.1	2.7	-	12.3	2.7	-	3.7	2.7	-	5.3	4.9	-	3.7	2.7	-	5.3	4.9	-			
19	4.2	-	-	4.6	-	-	5.6	-	-	1.7	-	-	2.4	-	-	1.7	-	-	2.4	-	-			
1	17.6	5.1	-	19.0	5.1	-	20.5	5.1	-	5.3	5.1	-	8.8	8.9	-	5.3	5.1	-	8.8	8.9	-			
25	8.0	-	-	8.6	-	-	9.3	-	-	2.4	-	-	4.0	-	-	2.4	-	-	4.0	-	-			
1¼	19.2	9.1	-	20.7	9.1	-	22.5	9.1	-	8.8	9.1	-	11.2	13.7	-	8.8	9.1	-	11.2	13.7	-			
32	8.7	-	-	9.4	-	-	10.2	-	-	4.0	-	-	5.1	-	-	4.0	-	-	5.1	-	-			
1½	26.0	14.0	-	29.8	14.0	-	34.0	14.0	-	11.2	14.0	-	19.2	21.9	-	11.2	14.0	-	19.2	21.9	-			
38	11.8	-	-	13.5	-	-	15.4	-	-	5.1	-	-	8.7	-	-	5.1	-	-	8.7	-	-			
2	31.1	22.4	-	38.8	22.4	-	53.6	22.4	-	19.4	22.4	-	33.7	40	-	19.4	22.4	-	33.7	40	-			
50	14.1	-	-	17.6	-	-	24.3	-	-	8.8	-	-	15.3	-	-	8.8	-	-	15.3	-	-			

SIZE	ASME 1500 & 1687												ASME 2500 & 2680										
	Bolted Bonnet						Welded Bonnet						Bolted Bonnet			Welded Bonnet							
	Standard Bore			Full Bore			Standard Bore			Full Bore			Standard Bore			Standard Bore							
in	WT	LB	WT	LB	C _v	WT	LB	C _v	WT	LB	C _v	WT	LB	C _v	WT	LB	C _v	WT	LB	C _v	WT	LB	C _v
mm	FE	KG	WE	KG		WE	KG		WE	KG		WE	KG		WE	KG		WE	KG		WE	KG	
¼	-	-	4.9	-	0.7	-	-	-	4.4	-	0.7	-	-	-	-	-	-	-	-	-	-	-	-
6	-	-	2.2	-	-	-	-	-	2.0	-	-	-	-	-	-	-	-	-	-	-	-	-	-
¾	-	-	4.4	-	1.5	-	-	-	4.4	-	1.5	-	-	-	-	-	-	-	-	-	-	-	-
10	-	-	2.0	-	-	-	-	-	2.0	-	-	-	-	-	-	-	-	-	-	-	-	-	-
½	20.3	-	4.9	-	1.5	6.0	-	1.5	4.4	-	1.5	6.0	-	1.5	16.1	-	1.8	14.3	-	3.0	-	-	-
13	9.2	-	2.2	-	-	2.7	-	-	2.0	-	-	2.7	-	-	7.3	-	-	6.5	-	-	-	-	-
¾	24.3	-	6.0	-	2.7	9.5	-	2.7	6.0	-	2.7	9.5	-	2.7	16.1	-	1.9	14.3	-	3.1	-	-	-
19	11.0	-	2.7	-	-	4.3	-	-	2.7	-	-	4.3	-	-	7.3	-	-	6.5	-	-	-	-	-
1	31.3	-	9.7	-	5.1	13.7	-	5.1	9.7	-	5.1	13.7	-	5.1	25.4	-	3.2	23.1	-	6.0	-	-	-
25	14.2	-	4.4	-	-	6.2	-	-	4.4	-	-	6.2	-	-	11.5	-	-	10.5	-	-	-	-	-
1¼	34.8	-	13.9	-	9.1	22.5	-	9.1	13.9	-	9.1	22.5	-	9.1	41.7	-	4.3	38.6	-	10.5	-	-	-
32	15.8	-	6.3	-	-	10.2	-	-	6.3	-	-	10.2	-	-	18.9	-	-	17.5	-	-	-	-	-
1½	47.0	-	22.7	-	14.0	33.7	-	14.0	22.7	-	14.0	33.7	-	14.0	41.7	-	10.7	38.6	-	13.5	-	-	-
38	21.3	-	10.3	-	-	15.3	-	-	10.3	-	-	15.3	-	-	18.9	-	-	17.5	-	-	-	-	-
2	61.3	-	33.7	-	22.4	36.8	-	22.4	33.7	-	22.4	36.8	-	22.4	58.9	-	14.2	62.8	-	22.4	-	-	-
50	27.8	-	15.3	-	-	16.7	-	-	15.3	-	-	16.7	-	-	26.7	-	-	28.5	-	-	-	-	-

FE = Flanged Ends
WE = Socket Weld / Threaded Ends

WT = Weight
C_v = Flow Coefficient

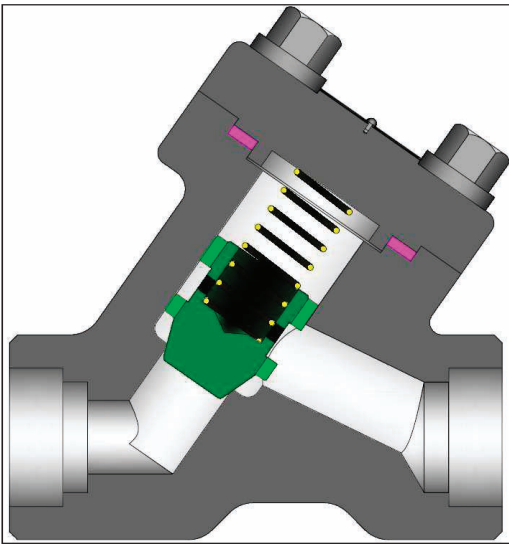

STANDARD MATERIALS (Other materials available)

PART	MATERIALS			
Body	A105 + Stellite 6 Faced	A182 F11 + Stellite 6 Faced	A182 F22 + Stellite 6 Faced	A182 F316 (1)
Cap	A105	A182 F11	A182 F22	A182 F316
Disc/Ball	A276 T420			A276 T316
Gasket (2)	Spiral Wound SST with Graphite			Spiral Wound SST with PTFE
Spring	Inconel 625			
Body / Cap Bolting (2)	A193 Gr. B7	A193 Gr. B16		A193 Gr. B8M
Identification Plate	Series 300 SST			

Class	Bore	Fig. No.
800	Standard	YL08
	Full	YLL8
1500	Standard	YL15
	Full	YLL5
1680	Standard	YL16
2500	Standard	YL25
2690	Standard	YL26

- (1) Threaded and weld end valve bodies A182 F316L
- (2) Welded bonnets also available.

Design Specifications

Item	Applicable Specification
Wall thickness	API 602
Pressure - temperature ratings	ASME B16.34
General valve design	API 602 & B16.34
End to End dimensions	ASME B16.10
Flange design	ASME B16.5
Thread design	ASME B1.20.1
Butt Weld design	ASME B16.25
Socket Weld design	ASME B16.11
Materials	ASTM

NOTE: See page 43 for flow, safety and maintenance information.

DESIGN FEATURES:

- **Standard trim** is stellite faced seat integral to the body and 13% chrome disc (API trim 8). Other trims available on request.
- **Seat faces** lapped for smooth finish and superior sealing.
- **Wall thickness** per heavy wall API 602 requirements.
- **Each** valve is shell and seat pressure tested per industry standard API 598.
- **Check** valve are suitable for service in horizontal line with cap vertical or in a vertical line with flow upward.
- **End Flanges** have the following raised faces per ASME B16.5:
Classes 150-300: 1/16" (2mm).
Classes 600: 1/4" (7mm).
- **Y-Pattern** features reduced flow restrictions compared to the upright design.
- **Other** available options as follows:
-Alternate valve materials such as chrome and stainless steel alloys.
-Alternate trim materials.
-NACE service.
-Special cleaning for applications such as oxygen or chlorine.
-Other options available as specified.

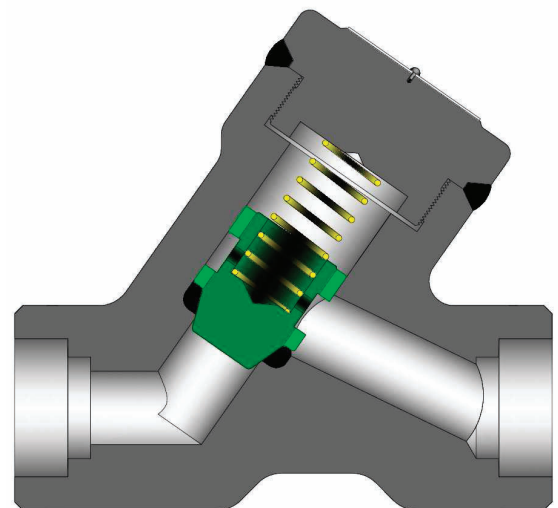

Welded Bonnet Design

Y-PATTERN PISTON CHECK VALVE DIMENSIONS (CLASS 800—2680).

SIZE	ASME 800					
	Bolted Bonnet			Welded Bonnet		
	Standard Bore			Standard Bore		
in	A	C	D	A	C	D
mm	WE			WE		
½	4.17	3.5	0.39	4.17	3.0	0.39
13	106	88	10	106	77	10
¾	4.17	3.5	0.50	4.17	3.0	0.50
19	106	88	13	106	77	13
1	4.72	4.0	0.69	4.72	3.5	0.69
25	120	101	18	120	88	18
1¼	5.98	4.9	0.91	5.98	4.3	0.91
32	152	124	23	152	108	23
1½	5.98	4.9	1.12	5.98	4.3	1.12
38	152	124	29	152	108	29
2	7.09	5.9	1.38	7.09	4.9	1.38
50	180	142	35	180	124	35

SIZE	ASME 1500 & 1690						ASME 2500 & 2680		
	Bolted Bonnet			Welded Bonnet			Welded Bonnet		
	Standard Bore			Standard Bore			Standard Bore		
in	A	C	D	A	C	D	A	C	D
mm	WE			WE			WE		
½	4.72	4.1	0.39	4.72	3.5	0.39	5.98	4.4	0.43
13	120	103	10	120	88	10	152	111	11
¾	4.72	4.1	0.50	4.72	3.5	0.50	5.98	4.4	0.55
19	120	103	13	120	88	13	152	111	14
1	5.98	5.0	0.69	5.98	4.3	0.69	7.09	5.0	0.75
25	152	126	18	152	108	18	180	128	19
1¼	5.98	5.7	0.91	5.98	4.3	0.91	7.87	5.7	0.98
32	152	146	23	152	108	23	200	145	25
1½	7.09	5.7	1.12	7.09	4.9	1.12	7.87	5.7	1.10
38	180	146	29	180	124	29	200	145	28
2	7.87	6.6	1.38	7.87	5.7	1.38	9.06	6.3	1.38
50	200	168	35	200	144	35	230	160	35

WE = Socket Weld / Threaded Ends

C = Center to top open

**ADDITIONAL MATERIALS AND CLASSES
AVAILABLE UPON REQUEST.**

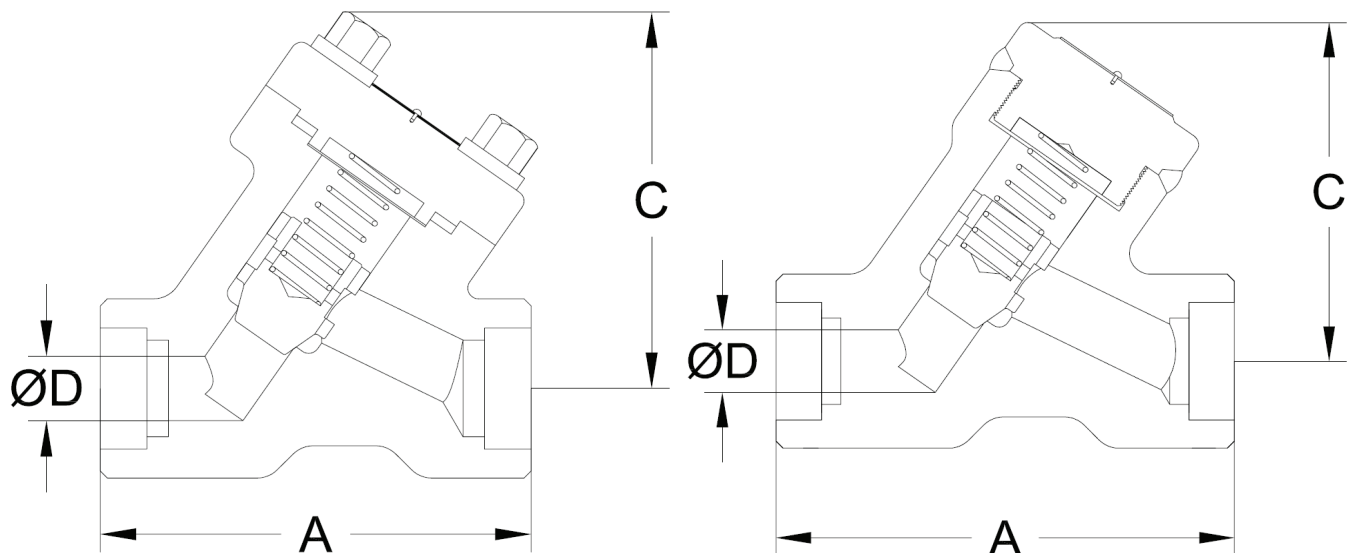



API 602 Y-PATTERN PISTON CHECK VALVES
 FORGED CARBON , STAINLESS STEEL OR ALLOY STEEL
 ¼" TO 2" (6 TO 50 mm)
 ASME CLASSES 800 TO 2680

SIZE	ASME 800					
	Bolted Bonnet			Welded Bonnet		
	Standard Bore			Standard Bore		
in	WT	LB	C _v	WT	LB	C _v
mm	WE	KG		WE	KG	
½	3.1		1.5	2.6		1.5
13	1.4			1.2		
¾	4.2		2.7	2.6		2.7
19	1.9			1.2		
1	5.7		5.1	4.4		5.1
25	2.6			2.0		
1¼	9.3		9.1	7.3		9.1
32	4.2			3.3		
1½	11.7		14.0	11.0		14.0
38	5.3			5.0		
2	19.8		22.4	15.4		22.4
50	9.0			7.0		

SIZE	ASME 1500 & 1687						ASME 2500 & 2680		
	Bolted Bonnet			Welded Bonnet			Welded Bonnet		
	Standard Bore			Standard Bore			Standard Bore		
in	WT	LB	C _v	WT	LB	C _v	WT	LB	C _v
mm	WE	KG		WE	KG		WE	KG	
½	5.7		1.5	4.4		1.5	7.7		3.0
13	2.6			2.0			3.5		
¾	5.7		2.7	4.4		2.7	7.7		3.1
19	2.6			2.0			3.5		
1	9.3		5.1	7.3		5.1	13.7		6.0
25	4.2			3.3			6.2		
1¼	11.7		9.1	9.3		9.1	22.9		10.5
32	5.3			4.2			10.4		
1½	19.8		14.0	15.4		14.0	22.9		13.5
38	9.0			7.0			10.4		
2	25.4		22.4	20.9		22.4	32.2		22.4
50	11.5			9.5			14.6		

WE = Socket Weld / Threaded Ends

WT = Weight
 C_v = Flow Coefficient

FORGED CRYOGENIC VALVES

Valves in cold service can present an engineering challenge because of the fragility of the packing at continuously low temperatures. To combat this, Powell Valves offers an assortment of cryogenic valves that all come standard with an extended bonnet and stem. These extensions help to keep the packing away from the low temperatures of the cryogenic fluid and thus function safely and efficiently.

Features:

- ⇒ All cryogenic valves are specially processed and carefully cleaned and degreased in specialized clean areas. They are then sealed to prevent contamination.
- ⇒ Cryogenic valves can serve in temperatures as low as -423° F.
- ⇒ Powell welcomes the development of custom designs needed to accommodate unique customer needs.
- ⇒ Extended bonnets and stems provide an adequate distance for the packing to maintain the safety, integrity and efficiency of the valve.
- ⇒ Powell also provides non-extended cryogenic valves, but recommends their use in only intermittent and non-extreme cold uses.
- ⇒ At the customers' request, Powell also offers bonnet chamber ventilation in order to prevent excess pressure build up caused by trapped cryogenic liquids.

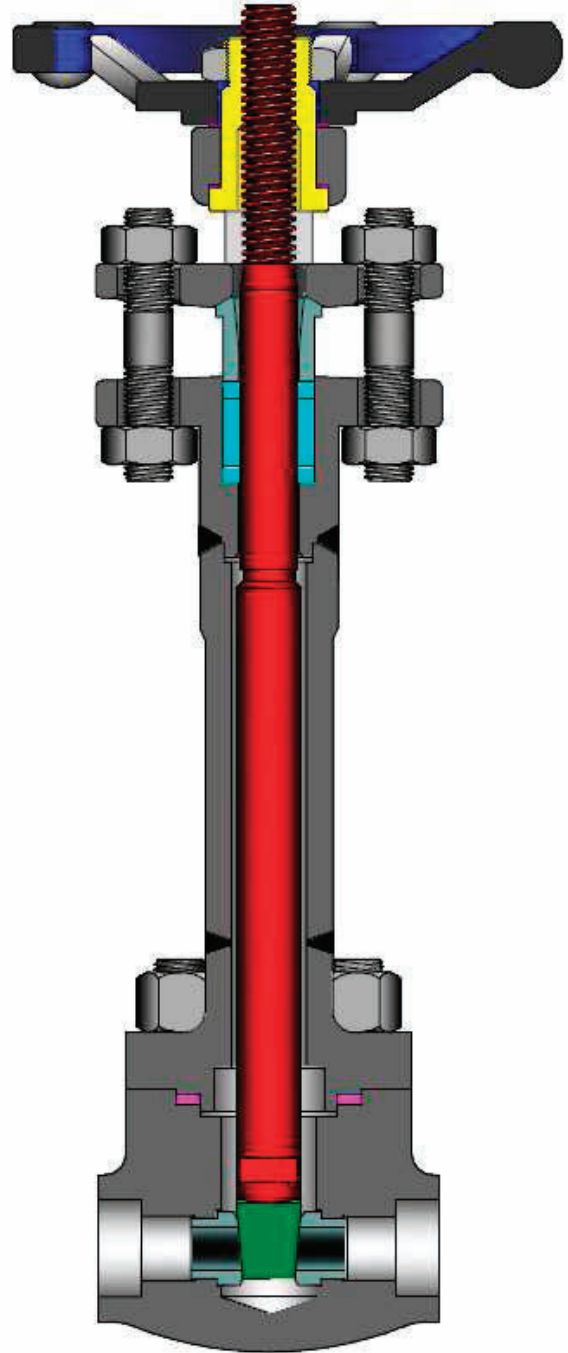

Cryogenic Forged Gate Valve

The quality and benefits expected of all Powell valves are extended and preserved with its cryogenic line.

For more information, see Powell's Cryogenic catalog.

FORGED BELLOSEAL VALVES

When sensitive services call for the best in leakage prevention, Powell Belloseal valves are the perfect answer. Whether it is preventing the exposure of harmful toxic fluids, maintaining high vacuums, or preventing the loss of high cost fluids, Powell Belloseal products are the ultimate valves in total fluid containment and durability. Bellows of the formed convolute type are closely secured to the bonnet and seal welded to the stem, creating a firm seal between the two while still allowing the opening and closing of the stem.

Features:

- ⇒ Bellows are designed to same pressure/temperature ranges of the valves they inhabit.
- ⇒ In addition to the primary bellows seal, Powell Belloseal valves maintain a secondary packing seal. This additional seal allows safe operation of the valve in the event of a bellows failure until the bellows can be replaced.
- ⇒ All Powell Belloseals are built in accordance of MSS SP-117 and API 602 specifications.

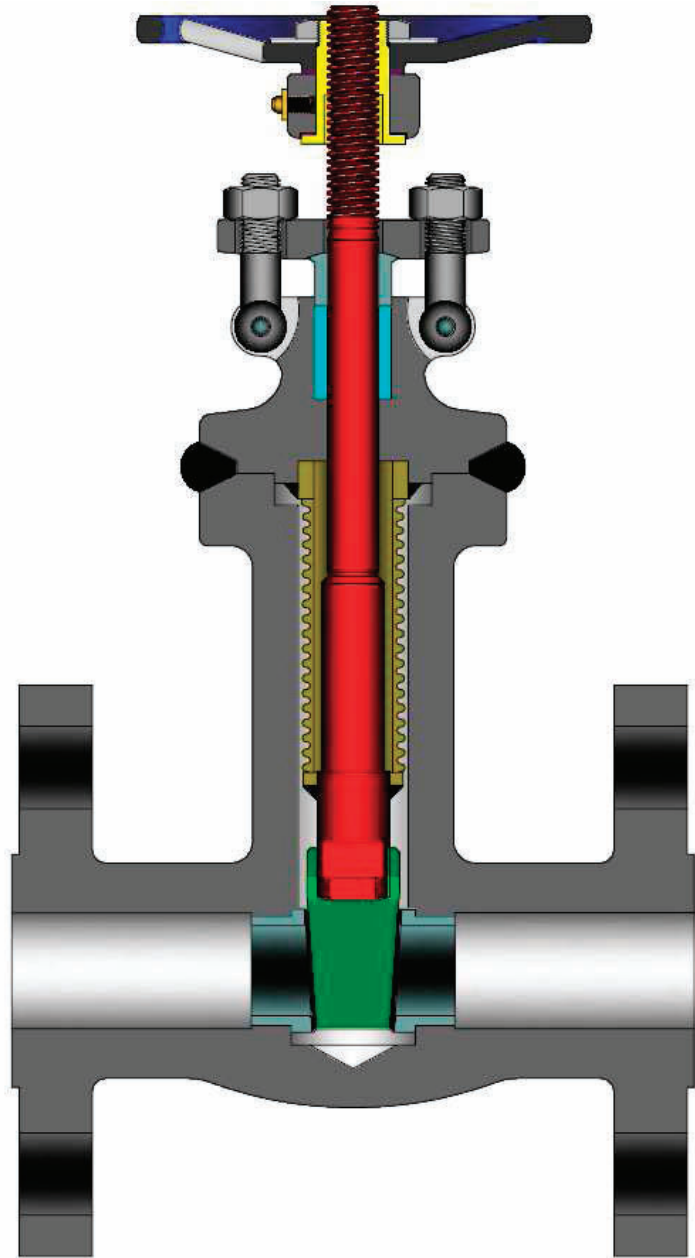

The quality and benefits expected of all Powell valves are extended and preserved with its Belloseal line.

For more information, see Powell's Belloseal brochure.

PAGE

VALVE STANDARDS AND RELATED INFORMATION

31

VALVE PRESSURE/TEMPERATURE RATINGS

32-37

CHEMICAL AND PHYSICAL PROPERTIES

38

TRIM DESCRIPTIONS

39

SOCKET WELD END DIMENSIONS

40

FLANGE DIMENSIONS

41-42

FLOW DESIGN AND MAINTENANCE RECOMMENDATIONS

43

CONVERSION DATA AND EQUIVALENTS

44-45

NOTE: DATA PROVIDED IN THIS SECTION IS FOR REFERENCE PURPOSES AND IS SUBJECT TO CHANGE. CONSULT CURRENT STANDARDS AND SPECIFICATIONS FOR THE LATEST DATA AND FOR SPECIFIC DETAILS WHICH MAY BE BEYOND THE SCOPE OF THIS CATALOG.

VALVE STANDARDS AND RELATED INFORMATION

1. Steel and Corrosion Resistant Designs

- (A) ASME B16.34 → Valves – Flanged, Threaded, and Welded End

This is the basic ASME valve standard for steel and corrosion resistant alloys. This standard contains requirements such as minimum shell wall thickness, pressure/temperature ratings, and pressure testing requirements.

- (B) API Standard 602 → Steel Gate, Globe, and Check Valves for Sizes NPS 4 (DN 100) and Smaller for the Petroleum and Natural Gas Industries

This is the basic standard for forged valves NPS 4 and under. It also defines the pressure/temperature ratings for the intermediate class 800.

- (C) API Standard 598 → Valve Inspection and Testing

This standard is referenced by both ASME B16.34 and API 602 and contains minimum inspection and pressure test requirements.

- (E) ASME B16.5 → Pipe Flanges and Flange Fittings

- (F) ASME B16.11 → Forged Fittings, Socket Welding and Threaded

- (G) MSS SP-25 → Standard Marking System for Valves, Fittings, Flanges and Unions

- (H) MSS SP-55 → Quality Standard for Steel Castings for Valves, Flanges, Fittings, and Other Piping Components

2. Powell Publications and Miscellaneous Information

The *Handbook of Valve Information* contains valve selection, storage, installation, operation, and maintenance information for all Powell Valves.

NOTE: Prior to any installation or maintenance, appropriate precautions must be followed. For example, all pressure must be relieved from the valve and affected piping prior to servicing and proper protective clothing and equipment must be worn.

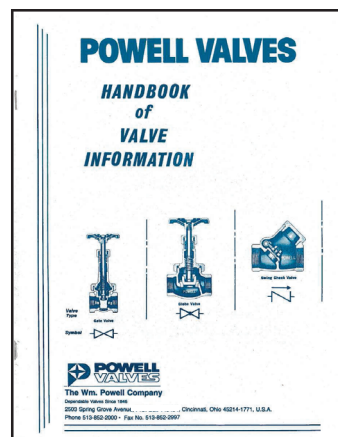

PRESSURE/TEMPERATURE RATINGS

TABLE 1

**ASTM A105
ASTM A350 LF2**

Upon prolonged exposure to temperatures above 800° F, the carbide phase of steel may be converted to graphite. Permissible, but not recommended for prolonged use above 800° F.

Working Pressures by Classes, psig							
Temperature, °F	150	300	600	800	1500	2500	4500
-20 to 100	285	740	1,480	1,975	3,705	6,170	11,110
200	260	680	1,360	1,810	3,395	5,655	10,185
300	230	655	1,310	1,745	3,270	5,450	9,815
400	200	635	1,265	1,690	3,170	5,280	9,505
500	170	605	1,205	1,610	3,015	5,025	9,040
600	140	570	1,135	1,515	2,840	4,730	8,515
650	125	550	1,100	1,465	2,745	4,575	8,240
700	110	530	1,060	1,415	2,665	4,425	7,960
750	95	505	1,015	1,350	2,535	4,230	7,610
800	80	410	825	1,100	2,055	3,430	6,170

TABLE 2

ASTM A182 F11

Use normalized and tempered material only. Not to be used over 1100° F.

Working Pressures by Classes, psig							
Temperature, °F	150	300	600	800	1500	2500	4500
-20 to 100	290	750	1,500	2,000	3,750	6,250	11,250
200	260	750	1,500	2,000	3,750	6,250	11,250
300	230	720	1,445	1,925	3,610	6,015	10,830
400	200	695	1,385	1,850	3,465	5,775	10,400
500	170	665	1,330	1,775	3,325	5,540	9,965
600	140	605	1,210	1,615	3,025	5,040	9,070
650	125	590	1,175	1,570	2,940	4,905	8,825
700	110	570	1,135	1,515	2,840	4,730	8,515
750	95	530	1,065	1,420	2,660	4,430	7,970
800	80	510	1,015	1,355	2,540	4,230	7,610
850	65	485	975	1,300	2,435	4,060	7,305
900	50	450	900	1,200	2,245	3,745	6,740
950	35	320	640	850	1,595	2,655	4,785
1000	20	215	430	575	1,080	1,800	3,240
1050	20(1)	145	290	385	720	1,200	2,160
1100	20(1)	95	190	255	480	800	1,440

NOTE: (1) For welding end valves only. Flanged end rating terminate at 1000° F.

PRESSURE/TEMPERATURE RATINGS

TABLE 3

ASTM A182 F22

Not to be used over 1100° F.

Working Pressures by Classes, psig							
Temperature, °F	150	300	600	800	1500	2500	4500
-20 to 100	290	750	1,500	2,000	3,750	6,250	11,250
200	260	750	1,500	2,000	3,750	6,250	11,250
300	230	730	1,455	1,940	3,640	6,070	10,925
400	200	705	1,410	1,880	3,530	5,880	10,585
500	170	665	1,330	1,775	3,325	5,540	9,965
600	140	605	1,210	1,615	3,025	5,040	9,070
650	125	590	1,175	1,570	2,940	4,905	8,825
700	110	570	1,135	1,515	2,840	4,730	8,515
750	95	530	1,065	1,420	2,660	4,430	7,970
800	80	510	1,015	1,355	2,540	4,230	7,610
850	65	485	975	1,300	2,435	4,060	7,305
900	50	450	900	1,200	2,245	3,745	6,740
950	35	385	755	1,025	1,930	3,220	5,795
1000	20	265	535	710	1,335	2,230	4,010
1050	20(1)	175	350	465	875	1,455	2,625
1100	20(1)	110	220	295	550	915	1,645

TABLE 4

ASTM A182 F5

Working Pressures by Classes, psig							
Temperature °F	150	300	600	800	1500	2500	4500
-20 to 100	290	750	1,500	2,000	3,750	6,250	11,250
200	260	735	1,470	1,965	3,680	6,135	11,040
300	230	700	1,400	1,865	3,495	5,830	10,490
400	200	670	1,335	1,780	3,345	5,570	10,030
500	170	645	1,290	1,725	3,230	5,385	9,690
600	140	605	1,210	1,615	3,025	5,040	9,070
650	125	590	1,175	1,570	2,940	4,905	8,825
700	110	570	1,135	1,515	2,840	4,730	8,515
750	95	530	1,065	1,420	2,660	4,430	7,970
800	80	510	1,015	1,355	2,540	4,230	7,610
850	65	485	975	1,300	2,435	4,060	7,305
900	50	375	745	995	1,870	3,115	5,605
950	35	275	550	735	1,370	2,285	4,115
1000	20	200	400	530	995	1,655	2,985
1050	20(1)	145	290	385	720	1,200	2,160
1100	20(1)	95	190	255	480	800	1,440
1150	20(1)	60	125	165	310	515	925
1200	15(1)	35	70	95	170	285	515

NOTE: (1) For welding end valves only. Flanged end rating terminate at 1000° F.

PRESSURE/TEMPERATURE RATINGS

TABLE 5

ASTM A182 F9

Working Pressures by Classes, psig							
Temperature °F	150	300	600	800	1500	2500	4500
-20 to 100	290	750	1,500	2,000	3,750	6,250	11,250
200	260	750	1,500	2,000	3,750	6,250	11,250
300	230	730	1,455	1,940	3,640	6,070	10,925
400	200	705	1,410	1,880	3,530	5,880	10,585
500	170	665	1,330	1,775	3,325	5,540	9,965
600	140	605	1,210	1,615	3,025	5,040	9,070
650	125	590	1,175	1,570	2,940	4,905	8,825
700	110	570	1,135	1,515	2,840	4,730	8,515
750	95	530	1,065	1,420	2,660	4,430	7,970
800	80	510	1,015	1,355	2,540	4,230	7,610
850	65	485	975	1,300	2,435	4,060	7,305
900	50	450	900	1,200	2,245	3,745	6,740
950	35	375	755	1,005	1,885	3,145	5,655
1000	20	255	505	675	1,270	2,115	3,805
1050	20(1)	170	345	460	855	1,430	2,570
1100	20(1)	115	225	300	565	945	1,695
1150	20(1)	75	150	200	375	630	1,130
1200	20(1)	50	105	140	255	430	770

TABLE 6

ASTM A182 F91

Working Pressures by Classes, psig							
Temperature °F	150	300	600	800	1500	2500	4500
-20 to 100	290	750	1,500	2,000	3,750	6,250	11,250
200	260	750	1,500	2,000	3,750	6,250	11,250
300	230	730	1,455	1,945	3,640	6,070	10,925
400	200	705	1,410	1,880	3,530	5,880	10,585
500	170	665	1,330	1,775	3,325	5,540	9,965
600	140	605	1,210	1,615	3,025	5,040	9,070
650	125	590	1,175	1,570	2,940	4,905	8,825
700	110	570	1,135	1,515	2,840	4,730	8,515
750	95	530	1,065	1,420	2,660	4,430	7,970
800	80	510	1,015	1,355	2,540	4,230	7,610
850	65	485	975	1,300	2,435	4,060	7,305
900	50	450	900	1,200	2,245	3,745	6,740
950	35	385	775	1,035	1,930	3,220	5,795
1000	20	365	725	970	1,820	3,030	5,450
1050	20(1)	360	720	960	1,800	3,000	5,400
1100	20(1)	300	605	805	1,510	2,515	4,525
1150	20(1)	225	445	595	1,115	1,855	3,345
1200	20(1)	145	290	385	720	1,200	2,160

NOTE: (1) For welding end valves only. Flanged end rating terminate at 1000° F.

PRESSURE/TEMPERATURE RATINGS

TABLE 7

ASTM A182 F316

At temperatures over 1000° F, use only when the carbon content is 0.04% or higher. This requirement must be specified by customer when applicable.

Working Pressures by Classes, psig							
Temperature, °F	150	300	600	800	1500	2500	4500
-20 to 100	275	720	1,440	1,920	3,600	6,000	10,800
200	235	620	1,240	1,655	3,095	5,160	9,290
300	215	560	1,120	1,495	2,795	4,660	8,390
400	195	515	1,025	1,370	2,570	4,280	7,705
500	170	480	955	1,275	2,390	3,980	7,165
600	140	450	900	1,205	2,255	3,760	6,770
650	125	440	885	1,180	2,210	3,680	6,625
700	110	435	870	1,160	2,170	3,620	6,515
750	95	425	855	1,140	2,135	3,560	6,410
800	80	420	845	1,125	2,110	3,520	6,335
850	65	420	835	1,115	2,090	3,480	6,265
900	50	415	830	1,105	2,075	3,460	6,230
950	35	385	775	1,030	1,930	3,220	5,795
1000	20	365	725	970	1,820	3,030	5,450
1050	20(1)	360	720	960	1,800	3,000	5,400
1100	20(1)	305	610	815	1,525	2,545	4,575
1150	20(1)	235	475	630	1,185	1,970	3,550
1200	20(1)	185	370	495	925	1,545	2,775
1250	20(1)	145	295	390	735	1,230	2,210
1300	20(1)	115	235	310	585	970	1,750
1350	20(1)	95	190	255	480	800	1,440
1400	20(1)	75	150	200	380	630	1,130
1450	20(1)	60	115	155	290	485	875
1500	15(1)	40	85	110	205	345	620

TABLE 8

ASTM A182 F304

At temperatures over 1000° F, use only when the carbon content is 0.04% or higher. This requirement must be specified by customer when applicable.

Working Pressures by Classes, psig							
Temperature, °F	150	300	600	800	1500	2500	4500
-20 to 100	275	720	1,440	1,920	3,600	6,000	10,800
200	230	600	1,200	1,600	3,000	5,000	9,000
300	205	540	1,075	1,435	2,690	4,480	8,065
400	190	495	995	1,325	2,485	4,140	7,450
500	170	465	930	1,240	2,330	3,880	6,985
600	140	440	885	1,180	2,210	3,680	6,625
650	125	430	865	1,150	2,160	3,600	6,480
700	110	420	845	1,125	2,110	3,520	6,335
750	95	415	825	1,100	2,065	3,440	6,190
800	80	405	810	1,080	2,030	3,380	6,085
850	65	395	790	1,055	1,980	3,300	5,940
900	50	390	780	1,035	1,945	3,240	5,830
950	35	380	765	1,020	1,910	3,180	5,725
1000	20	355	710	945	1,770	2,950	5,315
1050	20(1)	325	650	865	1,630	2,715	4,885
1100	20(1)	255	515	685	1,285	2,145	3,855
1150	20(1)	205	410	545	1,030	1,715	3,085
1200	20(1)	165	330	440	825	1,370	2,470
1250	20(1)	135	265	355	670	1,115	2,005
1300	20(1)	115	225	300	565	945	1,695
1350	20(1)	95	185	250	465	770	1,390
1400	20(1)	75	150	200	380	630	1,130
1450	20(1)	60	115	155	290	485	875
1500	15(1)	40	85	110	205	345	620

NOTE: (1) For welding end valves only. Flanged end rating terminate at 1000° F.

PRESSURE/TEMPERATURE RATINGS

TABLE 9

**ASTM A182 F316L
ASTM A182 F304L (a)**

(a) Not to be used over 800° F.

Working Pressures by Classes, psig							
Temperature, °F	150	300	600	800	1500	2500	4500
-20 to 100	230	600	1,200	1,600	3,000	5,000	9,000
200	195	510	1,020	1,365	2,555	4,260	7,670
300	175	455	910	1,215	2,280	3,800	6,840
400	160	420	840	1,120	2,100	3,500	6,300
500	150	395	785	1,050	1,970	3,280	5,905
600	140	370	745	990	1,860	3,100	5,580
650	125	365	730	975	1,825	3,040	5,470
700	110	360	720	960	1,800	3,000	5,400
750	110	355	705	940	1,765	2,940	5,290
800	80	345	690	920	1,730	2,880	5,185
850	65	340	675	900	1,690	2,820	5,075

TABLE 10

ASTM A182 F321

Not to be used over 1000° F.

Working Pressures by Classes, psig							
Temperature, °F	150	300	600	800	1500	2500	4500
-20 to 100	275	720	1,440	1,920	3,600	6,000	10,800
200	250	650	1,295	1,730	3,240	5,400	9,720
300	230	595	1,190	1,585	2,975	4,960	8,930
400	200	550	1,105	1,470	2,760	4,600	8,280
500	170	515	1,030	1,375	2,580	4,300	7,740
600	140	485	975	1,300	2,435	4,060	7,310
650	125	475	950	1,265	2,375	3,960	7,130
700	110	465	930	1,240	2,330	3,880	6,985
750	95	460	915	1,220	2,290	3,820	6,875
800	80	450	900	1,205	2,255	3,760	6,770
850	65	445	895	1,190	2,230	3,720	6,695
900	50	440	885	1,180	2,210	3,680	6,625
950	35	385	775	1,030	1,930	3,220	5,795
1000	20	365	725	970	1,820	3,030	5,450

PRESSURE/TEMPERATURE RATINGS

TABLE 11

ASTM A182 F347

Not to be used over 1000° F.

Working Pressures by Classes, psig

Temperature, °F	150	300	600	800	1500	2500	4500
-20 to 100	275	720	1,440	1,920	3,600	6,000	10,800
200	255	660	1,325	1,765	3,310	5,520	9,935
300	230	615	1,235	1,645	3,085	5,140	9,250
400	200	575	1,150	1,535	2,880	4,800	8,640
500	170	540	1,085	1,445	2,710	4,520	8,135
600	140	515	1,030	1,375	2,580	4,300	7,740
650	125	505	1,015	1,350	2,530	4,220	7,595
700	110	495	995	1,325	2,485	4,140	7,450
750	95	490	985	1,310	2,460	4,100	7,380
800	80	485	975	1,300	2,435	4,060	7,310
850	65	485	970	1,295	2,425	4,040	7,270
900	50	450	900	1,200	2,245	3,745	6,740
950	35	385	775	1,030	1,930	3,220	5,795
1000	20	365	725	970	1,820	3,030	5,450

CHEMICAL AND PHYSICAL PROPERTIES
CAST CARBON AND ALLOY STEELS

TABLE 12

ASTM STANDARD GRADE		A105 ***	A182 F11 Cl. 2	A182 F22 Cl. 3	A182 F5	A182 F9	A182 F91**	A182 F316L	A182 F316	A182 F304L	A182 F304	A182 F321	A182 F347
CARBON (C)	(Min)	-	0.10	0.05	-	-	0.08	-	-	-	-	-	-
	(Max)	0.35	0.20	0.15	0.15	0.15	0.12	0.030	0.08	0.030	0.08	0.08	0.08
MANGANESE (Mn)	(Min)	0.60	0.30	0.30	0.30	0.30	0.30	-	-	-	-	-	-
	(Max)	1.05	0.80	0.60	0.60	0.60	0.60	2.00	2.00	2.00	2.00	2.00	2.00
PHOSPHORUS (P)	(Min)	-	-	-	-	-	-	-	-	-	-	-	-
	(Max)	0.035	0.040	0.040	0.030	0.030	0.020	0.045	0.045	0.045	0.045	0.045	0.045
SULFUR (S)	(Min)	-	-	-	-	-	-	-	-	-	-	-	-
	(Max)	0.040	0.040	0.040	0.030	0.030	0.010	0.030	0.030	0.030	0.030	0.030	0.030
SILICON (Si)	(Min)	0.10	0.50	-	-	0.50	0.20	-	-	-	-	-	-
	(Max)	0.35	1.00	0.50	0.50	1.00	0.50	1.00	1.00	1.00	1.00	1.00	1.00
COPPER (Cu)	(Min)	-	-	-	-	-	-	-	-	-	-	-	-
	(Max)	0.40*	-	-	-	-	-	-	-	-	-	-	-
NICKEL (Ni)	(Min)	-	-	-	-	-	-	10.0	10.0	8.0	8.0	9.0	9.0
	(Max)	0.40*	-	-	0.5	-	0.40	15.0	14.0	13.0	11.0	12.0	13.0
CHROMIUM (Cr)	(Min)	-	1.00	2.00	4.0	8.0	8.0	16.0	16.0	18.0	18.0	17.0	17.0
	(Max)	0.30*@	1.50	2.50	6.0	10.0	9.5	18.0	18.0	20.0	20.0	19.0	20.0
MOLYBDENUM (Mo)	(Min)	-	0.44	0.87	0.44	0.90	0.85	2.00	2.00	-	-	-	-
	(Max)	0.12*@	0.65	1.13	0.65	1.10	1.05	3.00	3.00	-	-	-	-
VANADIUM (V)	(Min)	-	-	-	-	-	0.18	-	-	-	-	-	-
	(Max)	0.08*	-	-	-	-	0.25	-	-	-	-	-	-
TITANIUM (Ti)	(Min)	-	-	-	-	-	-	-	-	-	-	\$	-
	(Max)	-	-	-	-	-	0.01	-	-	-	-	0.70	-
NITROGEN (N)	(Min)	-	-	-	-	-	0.03	-	-	-	-	-	-
	(Max)	-	-	-	-	-	0.07	0.10	0.10	0.10	0.10	-	-
COLUMBIUM (Cb)	(Min)	-	-	-	-	-	0.06	-	-	-	-	-	#
	(Max)	-	-	-	-	-	0.10	-	-	-	-	-	1.10
TENSILE STRENGTH	(Min)	70 Ksi	70 Ksi	75 Ksi	70 Ksi	85 Ksi	90 Ksi	70 Ksi	75 Ksi	70 Ksi	75 Ksi	75 Ksi	75 Ksi
YIELD STRENGTH	(Min)	36 Ksi	40 Ksi	45 Ksi	40 Ksi	55 Ksi	60 Ksi	25 Ksi	30 Ksi	25 Ksi	30 Ksi	30 Ksi	30 Ksi
ELONGATION	(Min)	30%	20%	20%	20%	20%	20%	30%	30%	30%	30%	30%	30%
REDUCTION OF AREA	(Min)	30%	30%	30%	35%	40%	40%	50%	50%	50%	50%	50%	50%
TEMPERATURE	(Min)+	-20F	-20F	-20F	-20F	-20F	-20F	-425F	-425F	-425F	-425F	-425F	-425F
	(Max)	800F	1100F	1100F	1200F	1200F	1200F	850F	1500F [‡]	850F	1500F [‡]	1000F	1000F

* RESIDUAL ELEMENTS-Maximum total must not exceed 1.00%.

** ALUMINUM is 0.02% max and ZIRCONIUM is 0.01% max.

*** The maximum MANGANESE may increase 0.04%, up to 1.28% maximum, for each reduction of 0.01% below the specified maximum CARBON content.

+ For temperatures below -50° F special cryogenic cleaning may be required. For temperatures below -100° F, special cryogenic extensions may be required. See Cryogenic section of catalog for more information.

@ The sum of CHROMIUM and MOLYBDENUM shall not exceed 0.32%.

\$ TITANIUM content shall not be less than five times the CARBON content.

COLUMBIUM content shall not be less than ten times the CARBON content.

[‡] For temperatures over 1000° F, minimum CARBON is 0.04%. Customer must specify if temperature is over 1000° F and this minimum CARBON is required.

NOTE: Chemical Compositions Are In Units Of Percent.

TRIM DESCRIPTIONS

TABLE 13

API Trim No.	Powell Trim Designation	Seat Nominal Designation	Seat Nominal Composition	Nominal Hardness (HB)	Typical Stem/Backseat Material
1	1	F6	13 Cr	250 min (a)	TYPE 410 or 420 (13Cr)
2	E	304	18Cr-8Ni	-	TYPE 304(18Cr-8Ni)
5	5	Hardfaced	Co-CrA (b)	350	TYPE 410 or 420 (13 Cr)
8	8	F6 and	13 Cr.	250	TYPE 410 or 420 (13 Cr)
		Hardfaced	Co-CrA (b)	350	
9	9	Monel	Ni-Cu Alloy	-	Monel (Ni-Cu)
10	0	316	18Cr-8Ni-Mo	-	TYPE 316 (18Cr-8Ni-Mo)
11	D	Monel and	Ni-Cu Alloy	-	Monel (Ni-Cu)
		Hardfaced	Co-CrA (b)	350	
12	2	316 And	18Cr-8Ni-Mo	-	TYPE 316 (18Cr-8Ni-Mo)
		Hardfaced	Co-CrA (b)	350	
13	3	Alloy 20	19Cr-29Ni	-	Alloy 20 (19Cr-29Ni)
14	4	Alloy 20 and	19Cr-29Ni	-	Alloy 20 (19Cr-29Ni)
		Hardfaced	Co-CrA (b)	350	
15	U	Hardfaced	Co-Cr-A(b)	350	TYPE 304 (18Cr-8Ni)
16	6	Hardfaced	Co-Cr-A(b)	350	TYPE 316 (18Cr-8Ni-Mo)
17	7	Hardfaced	Co-Cr-A(b)	350	TYPE 347(18Cr-10Ni-Cb)
18	J	Hardfaced	Co-Cr-A(b)	350	Alloy 20 (19Cr-29Ni)
Integral ½HF	A	Equal to Body	Equal to Body	-	Equal to Body
		Hardfaced	Co-CrA (b)	350	
Integral Full HF	B	Hardfaced	Co-CrA (b)	350	Equal to Body
Integral	C	Equal to Body	Equal to Body	-	Equal to Body

(a) Minimum 50HB differential hardness between mating seating surfaces

(b) Stellite 6™ or equal.

SOCKET WELD END DIMENSIONS

TABLE 14

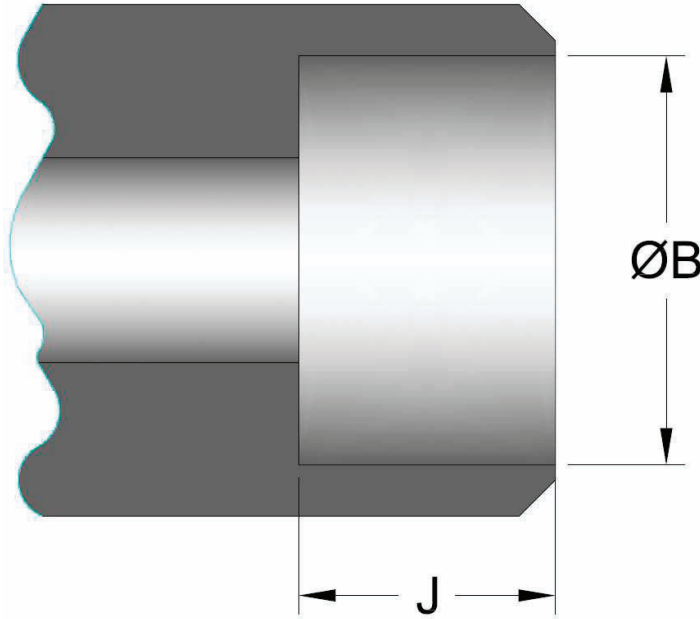

Data taken from tables
1 and I1 in ASME
B16.11

Size	English (in)			Metric (mm)		
	Socket Bore Diameter (B)	Max	Min Depth of Socket (J)	Socket Bore Diameter (B)	Max	Min Depth of Socket (J)
		Min			Min	
¼	0.575	0.38	14.6	9.5		
	0.555		14.2			
⅜	0.710	0.38	18.0	9.5		
	0.690		17.6			
½	0.875	0.38	22.2	9.5		
	0.855		21.8			
¾	1.085	0.50	27.6	12.5		
	1.065		27.2			
1	1.350	0.50	34.3	12.5		
	1.330		33.9			
1¼	1.695	0.50	43.1	12.5		
	1.675		42.7			
1½	1.935	0.50	49.2	12.5		
	1.915		48.8			
2	2.426	0.62	61.7	16.0		
	2.406		61.2			

NOTE: Powell reserves the right to convert threaded ends to socket weld, which may result in thread remnants as pipe stop.

STEEL VALVE FLANGE DIMENSIONS

All Dimensions in Units of Inches

TABLE 15

Classes 150 and 300 valves use flanged fitting dimensions.
Information taken from ASME B16.5.

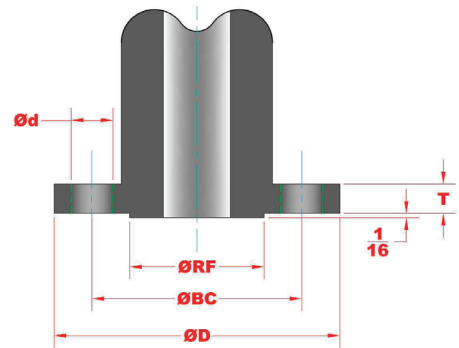

CLASS 150

Nominal Pipe Size	Outside Diameter of Flange (D)	Diameter of Bolt Circle (BC)	Diameter of Bolt Holes (d)	Number of Bolts	Thickness (T)	Raised Face Diameter (RF)
½	3.50	2.38	0.62	4	0.31	1.38
¾	3.88	2.75	0.62	4	0.34	1.69
1	4.25	3.12	0.62	4	0.38	2.00
1 ¼	4.62	3.50	0.62	4	0.44	2.50
1 ½	5.00	3.88	0.62	4	0.50	2.88
2	6.00	4.75	0.75	4	0.56	3.62

CLASS 300

Nominal Pipe Size	Outside Diameter of Flange (D)	Diameter of Bolt Circle (BC)	Diameter of Bolt Holes (d)	Number of Bolts	Thickness (T)	Raised Face Diameter (RF)
½	3.75	2.62	0.62	4	0.50	1.38
¾	4.62	3.25	0.75	4	0.56	1.69
1	4.88	3.50	0.75	4	0.62	2.00
1 ¼	5.25	3.88	0.75	4	0.69	2.50
1 ½	6.12	4.50	0.88	4	0.75	2.88
2	6.50	5.00	0.75	8	0.81	3.62

STEEL VALVE FLANGE DIMENSIONS

All Dimensions in Units of Inches

TABLE 16

Classes 600 and higher valves use flange dimensions.
Information taken from ASME B16.5.

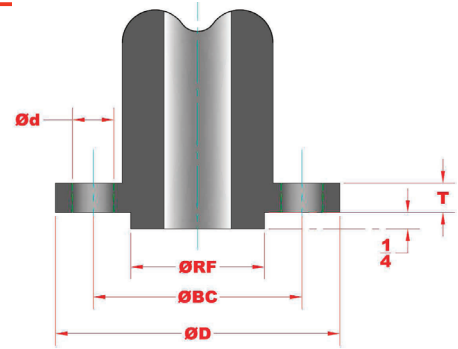

CLASS 600

Nominal Pipe Size	Outside Diameter of Flange (D)	Diameter of Bolt Circle (BC)	Diameter of Bolt Holes (d)	Number of Bolts	Thickness (T)	Raised Face Diameter (RF)
1/2	3.75	2.62	0.62	4	0.56	1.38
3/4	4.62	3.25	0.75	4	0.62	1.69
1	4.88	3.50	0.75	4	0.69	2.00
1 1/4	5.25	3.88	0.75	4	0.81	2.50
1 1/2	6.12	4.50	0.88	4	0.88	2.88
2	6.50	5.00	0.75	8	1.00	3.62

CLASS 1500

Nominal Pipe Size	Outside Diameter of Flange (D)	Diameter of Bolt Circle (BC)	Diameter of Bolt Holes (d)	Number of Bolts	Thickness (T)	Raised Face Diameter (RF)
1/2	4.75	3.25	0.88	4	0.88	1.38
3/4	5.12	3.50	0.88	4	1.00	1.69
1	5.88	4.00	1.00	4	1.12	2.00
1 1/4	6.25	4.38	1.00	4	1.12	2.50
1 1/2	7.00	4.88	1.12	4	1.25	2.88
2	8.50	6.50	1.00	8	1.50	3.62

FLOW DESIGN AND MAINTENANCE RECOMMENDATIONS

- (1) SWING CHECK VALVES- Minimum ½ psi differential pressure across valve to maintain proper “full open position.
- (2) LIFT CHECK AND NON-RETURN VALVES- Minimum 2 psi differential pressure across valve to maintain proper “full open position”
- (3) Recommended length of straight pipe before and after check and non-return valves to be 10 times pipe diameter to avoid flow turbulence at valve.
- (4) For metal seated check valves at low pressure applications (approximately 50 psi or less), seat leakage may be significantly greater than normal seat test allowable limit.
- (5) RECOMMENDED MAXIMUM FLOW VELOCITIES (APPROXIMATE):

<u>VALVE SIZE</u>	<u>WATER</u> (FT/MIN)	<u>SATURATED STEAM</u> (FT/MIN)	<u>SUPERHEATED STEAM</u> (FT/MIN)
3" and UNDER	1200	7200	9000
4	1200	8800	11000
6	1620	10400	13000
8	1860	12000	15000
10	2100	14400	18000
12	2220	15200	19000
14	2400	16000	20000
16	2400	17600	22000
18	2400	19200	24000
20" and LARGER	2400	20800	26000

- (6) GATE VALVES — Not to be used in throttling services. Open and closed services only.
- (7) GLOBE VALVES— Not to be throttled under 20% open.

**FOR MAINTENANCE AND SAFETY INFORMATION, SEE THE POWELL
HANDBOOK OF VALVE INFORMATION, AS DESCRIBED ON PAGE 30.**

COMPARISON CHART OF VALVE SIZE/NOMINAL PIPE SIZE

TABLE 17

<u>METRIC NOMINAL SIZE</u> (DN)	<u>ENGLISH NOMINAL SIZE</u> (NPS)
8	1/4
10	3/8
15	1/2
20	3/4
25	1
32	1-1/4
40	1-1/2
50	2
65	2-1/2
80	3
100	4
150	6
200	8
250	10
300	12
350	14
400	16
450	18
500	20
600	24

CONVERSION FACTORS

	TO CONVERT FROM	TO	MULTIPLY BY
LENGTH	INCHES (IN)	MILLIMETERS (MM)	25.4
	INCHES (IN)	CENTIMETERS (CM)	2.54
	FEET (FT)	INCHES (IN)	12
WEIGHT	POUNDS (LB)	KILOGRAMS (KG)	0.4536
	POUNDS (LB)	NEWTONS (N)	4.448
PRESSURE*	PSI	KILOGRAMS/M ²	703
	PSI	KILOGRAMS/CM ²	0.0703
	PSI	KILOGRAMS/MM ²	0.000703
	PSI	BAR	0.0689
	PSI	ATMOSPHERE	0.068
	PSI	KILOPASCAL	6.895
	PSI	MEGAPASCAL	0.006895
	PSI	NEWTON/MM ²	0.006895
	PSI	IN. WATER**	27.68
	PSI	FT. WATER**	2.307
	PSI	IN. MERCURY**	2.036
	PSF		144
AREA	SQ.INCH (IN ²)	SQ.CENTIMETERS (CM ²)	6.452

TEMPERATURE

TO CONVERT FROM DEGREES CENTIGRADE (C) TO DEGREES FAHRENHEIT (F): $F=1.8*C+32$

TO CONVERT FROM FAHRENHEIT (F) TO DEGREES CENTIGRADE (C): $C=0.556*(F-32)$

NOTE: MOST FACTORS ARE ROUNDED OFF AND NOT EXACT CONVERSIONS.

*- PSI = POUNDS PER SQUARE INCH AND PSF = POUNDS PER SQUARE FOOT.

**-. WATER AT 60F. MERCURY AT 32F.

MEASUREMENT EQUIVALENTS

FRACTION			DECIMAL	MILLIMETERS
		1/64	0.0156	0.3969
	1/32		0.0313	0.7938
			0.0394	1.0000
		3/64	0.0469	1.1906
1/16			0.0625	1.5875
		5/64	0.0781	1.9844
			0.0787	2.0000
	3/32		0.0938	2.3813
		7/64	0.1094	2.7781
			0.1181	3.0000
1/8			0.1250	3.1750
		9/64	0.1406	3.5719
	5/32		0.1563	3.9688
			0.1575	4.0000
		11/64	0.1719	4.3656
3/16			0.1875	4.7625
			0.1969	5.0000
		13/64	0.2031	5.1594
	7/32		0.2188	5.5563
		15/64	0.2344	5.9531
			0.2362	6.0000
1/4			0.2500	6.3500
		17/64	0.2656	6.7469
			0.2756	7.0000
	9/32		0.2813	7.1438
		19/64	0.2969	7.5406
5/16			0.3125	7.9375
			0.3150	8.0000
		21/64	0.3281	8.3344
	11/32		0.3438	8.7313
			0.3543	9.0000
		23/64	0.3594	9.1281
3/8			0.3750	9.5250
		25/64	0.3906	9.9219
			0.3937	10.0000
	13/32		0.4063	10.3188
		27/64	0.4219	10.7156
			0.4331	11.0000
7/16			0.4375	11.1125
		29/64	0.4531	11.5094
	15/32		0.4688	11.9063
			0.4724	12.0000
		31/64	0.4844	12.3031
1/2			0.5000	12.7000

FRACTION			DECIMAL	MILLIMETERS
			0.5118	13.0000
		33/64	0.5156	13.0969
	17/32		0.5313	13.4938
		35/64	0.5469	13.8906
			0.5512	14.0000
9/16			0.5625	14.2875
		37/64	0.5781	13.6844
			0.5906	15.0000
	19/32		0.5938	15.0813
		39/64	0.6094	15.4781
5/8			0.6250	15.8750
			0.6299	16.0000
		41/64	0.6406	16.2719
	21/32		0.6563	16.6688
			0.6693	17.0000
		43/64	0.6719	17.0656
11/16			0.6875	17.4625
		45/64	0.7031	17.8594
			0.7087	18.0000
	23/32		0.7188	18.2563
		47/64	0.7344	18.6531
			0.7480	19.0000
3/4			0.7500	19.0500
		49/64	0.7656	19.4469
	25/32		0.7813	19.8438
			0.7874	20.0000
		51/64	0.7969	20.2406
13/16			0.8125	20.6375
			0.8268	21.0000
		53/64	0.8281	21.0344
	27/32		0.8438	21.4313
		55/64	0.8594	21.8281
			0.8661	22.0000
7/8			0.8750	22.2250
		57/64	0.8906	22.6219
			0.9055	23.0000
	29/32		0.9063	23.0188
		59/64	0.9219	23.4156
15/16			0.9375	23.8125
			0.9449	24.0000
		61/64	0.9531	24.2094
	31/32		0.9688	24.6063
			0.9843	25.0000
		63/64	0.9844	25.0031
1			1.0000	25.4000

March, 2011 THE WILLIAM POWELL COMPANY

GENERAL TERMS AND CONDITIONS OF SALE

1. TERMS EXCLUSIVE: The terms and conditions of the purchase order or requisition to which these GENERAL TERMS AND CONDITIONS OF SALE (these "Terms and Conditions") relate or are attached (each, an "Order"), are exclusive and represent the full and final agreement of The William Powell Company, an Ohio corporation ("Powell") and the purchaser ("Purchaser") as they relate to the goods, materials, services or labor covered in the Order (all, whether or not tangible property or goods, the "Products"), and may not be added to, modified, superseded or altered except by written agreement or modification signed by Powell's authorized representative, notwithstanding any additional or other proposals, terms and conditions which may now or in the future appear on Purchaser's Orders or other forms (notification of objection thereto being given hereby), in whatever form transmitted, and notwithstanding any shipment of Products, acceptance of payments or other similar acts of Powell.

2. SALE BY AGENT OR REPRESENTATIVE: These Terms and Conditions shall govern the liability and obligations of Powell in regard to the transaction in Products, whether the sale was procured directly by Powell or indirectly through an authorized sales representative.

3. CONTRACT: Orders may be submitted to Powell in writing (which will include via an electronic transmission) or orally, provided, however, that if Purchaser fails to provide a detailed, formal written Order (a) within ten (10) days of an oral Order or (b) before shipment of the Order, whichever is earlier, then Product descriptions, quantities, specifications, etc., as set forth in Powell's acknowledgement, acceptance and/or invoice, shall be conclusive and binding on both parties, and discrepancies shall be for Purchaser's account. All Orders are subject to credit approval and acceptance by Powell. An Order shall be deemed to have been accepted by Powell upon the first to occur of the following: (i) Powell's first shipment or other tender of the Order or (ii) acceptance thereof by Powell in writing.

4. PERMISSIBLE VARIATIONS: Powell has the right, prior to the delivery of Products to Purchaser and without the giving of notice to Purchaser, to make any changes in the composition, fabrication or design of the Products which, in the opinion of Powell, do not affect the general characteristics or properties of the Products. In addition, Powell may make any change or any variation in the Products, whether of quality or quantity, which is within governmental or professional standards or specifications applicable at the time of manufacture without giving notice to Purchaser. Purchaser will accept any Products which may incorporate any changes in the composition, fabrication or design.

5. PRICES: Prices for Products are quoted and payable in U.S. dollars ("USD"). Prices stated in general price lists are subject to change without prior notice, at Powell's sole discretion. Prices that are provided in a specific quotation will remain firm for thirty (30) days of the issued date of the written quotation. All prices are exclusive of freight costs, taxes and duties. All taxes (including, without limitation, sales, use, stamp, value added and other taxes) duties, fees, charges and assessments by whomsoever levied on or with respect to the Products, and whether levied against Purchaser or Powell, are for Purchaser's account and, unless invoiced, shall be paid by Purchaser directly to the appropriate governmental agency.

6. SHIPPING TERMS: Delivery of Products to Canada, the United States and Mexico shall be F.O.B. (as defined in the Uniform Commercial Code as in effect in the State of Ohio) Powell's plant of manufacture. Delivery of Products outside of Canada, United States and Mexico shall be Ex Works (as defined by INCOTERMS 2000) Powell's plant of manufacture. All transportation expenses, freight and insurance shall be paid by Purchaser, and risk of delay, loss or damage incurred in transit shall be borne by Purchaser, who shall be responsible to file any such claims with the relevant carrier(s) or insurers.

Upon tender of delivery, title shall pass to Purchaser, subject to Powell's right of stoppage in transit and to Powell's security interest in the Products, as set forth in Section 8.

If the Products are held by Powell subject to receiving instructions from Purchaser or in any case where Powell, in its sole discretion, determines any part of the Products should be held for Purchaser's account, Powell may invoice the Products, and Purchaser agrees to make payment in accordance with these Terms and Conditions. Products invoiced and held at any location by Powell will be held at Purchaser's risk, and Powell may charge for (but is not obligated to carry) insurance and storage.

If Purchaser has declared or manifested an intention not to accept delivery in accordance with these Terms and Conditions, no tender will be necessary, but Powell may, at its option, give notice to Purchaser that Powell is ready and willing to deliver and such notice will constitute a valid tender of delivery.

7. INSPECTION AND ACCEPTANCE: Each shipment shall be inspected by Purchaser for observable damage and/or non-conformity at the time of delivery of the Products. Failure to so inspect shall constitute a waiver of Purchaser's rights of inspection and shall constitute an unqualified acceptance of the Products. If, after such inspection, Purchaser attempts to reject any Products, Purchaser shall fully specify all claimed damage or non-conformity in writing in a notice of rejection sent to Powell within five (5) days of delivery of the Products. Purchaser's failure to so specify shall constitute a waiver of that damage or non-conformity. Partial deliveries shall be accepted by Purchaser and paid for according to these Terms and Conditions.

8. PAYMENT TERMS: Payment shall be due net thirty (30) days from the date of invoice. Overdue accounts shall be subject to a carrying charge of one and one-half percent (1.5%) per month or portion of a month on the unpaid balance until paid in full. In the event Purchaser shall default on its obligations hereunder, Purchaser shall be liable for all of Powell's costs and expenses of collection, including reasonable attorneys' fees. Powell may, at its option, cancel and/or sell any unshipped Products should Purchaser fail to fulfill the complete terms of payment. Purchaser will have no right to offset any amounts against any payment or other obligation which Powell may owe to Purchaser. Powell hereby reserves a security interest in the Products to secure Purchaser's payment of the purchase price and any other amounts owed by Purchaser, and Purchaser agrees that Powell may (but is not obligated to) take such action as Powell deems advisable to evidence and perfect such interest and that Purchaser will cooperate with Powell in the taking of such actions.

9. CREDIT APPROVAL: Notwithstanding the provisions of Section 8, Powell may at any time decline to make any shipment or delivery or perform any work except upon receipt of payment or upon terms and conditions or security satisfactory to Powell, including, but not limited to, requiring that Purchaser provide Powell one or more letters of credit.

10. LEAD TIMES: Estimated lead times, if specified, are approximate only and are not guaranteed. Failure to ship on or near the estimated date shall not entitle Purchaser to any remedy or to cancel the Order without charge. Estimated lead times are provided Ex Works Powell's plant in weeks after receipt of Order. Estimated lead times are stated on a net basis and do not include any additional lead time due to scheduled and/or unscheduled plant shutdowns. Scheduled plant shutdowns include a two (2) week shutdown each winter and each summer. Estimated lead times are quoted on the basis of material availability and plant loading at the time of quotation, which are subject to change. Purchaser should confirm any estimated lead times at time of Order.

11. MINIMUM ORDER CHARGE: With respect to any Order that includes spare, replacement or component parts ("Parts") as Products, a minimum Order charge of One Hundred USD (\$100) shall apply. With respect to any Order that includes valves ("Valves") as Products, a minimum Order charge of Three Hundred Fifty USD (\$350) shall apply.

12. RETURN OF PRODUCTS: No Products shall be returned to Powell without Powell's prior written agreement. Products returned by Purchaser shall be returned in the same condition as when delivery was affected by Powell. Only Products that are new, unused and in a condition suitable for immediate resale shall be considered for return. Powell reserves the right to assess a minimum thirty-five percent (35%) restocking charge for Products returned for reasons other than defects or non-conformity.

13. CANCELLATION/SUSPENSION: Purchaser shall not cancel or suspend an Order without Powell's prior written consent, which such consent Powell shall be under no obligation to provide. In the event of cancellation or suspension of an Order without Powell's prior written consent, in addition to Powell's other rights and remedies available hereunder and under applicable law, Purchaser shall pay cancellation charges as follows: (a) Order entered in Powell's system, but no engineering yet initiated, 5%, (b) Engineering work has begun and orders for casings and/or outside purchased parts have been placed, 25%, (c) Castings poured and/or components made, but not yet received at Powell's location, 75%, (d) Castings poured and/or components made and received at Powell's location, 85%, (e) Manufacturing process started, 95% and (f) Components finished, 100%.

Powell may cancel all or part of an Order immediately upon the happening of any of the following: Purchaser is delinquent on any of its obligations hereunder or under any order or transaction with Powell, insolvency of Purchaser; the appointment of a custodian as that term is defined in Title 11 U.S.C., as amended (the "Bankruptcy Code"), or the commencement of a case under any chapter of the Bankruptcy Code or the bankruptcy, receivership, insolvency or similar laws of any country for, by or against Purchaser; Purchaser's suspension or termination of business or assignment for the benefit of creditors; or any event, whether or not similar to the foregoing, which materially impairs Purchaser's ability to perform hereunder. Powell's rights to cancel or postpone set forth herein may be exercised by Powell without liability.

14. CORRECTIONS: Powell reserves the right to make corrections to price lists, quotations, invoices or other contract documents in the event of clerical or typographical errors.

15. COUNTRY OF ORIGIN: Powell reserves the right to furnish Products from any of its plants at its sole discretion and does not represent that the Products listed

herein originate from any specific country. Any costs affected by country of origin, including, but not limited to, customs duties, are not included in the purchase price and are for Purchaser's account.

16. INFORMATION REGARDING PRODUCTS: Purchaser acknowledges that it has received and is familiar with Powell's and any other manufacturer's labeling and literature concerning the Products and will forward such information to its employees, agents and customers.

17. POWELL PRODUCT WARRANTY: For a period of (a) ninety (90) days from tender of delivery with respect to Parts and (b) the earlier of (i) eighteen (18) months from tender of delivery or (ii) twelve (12) months from installation with respect to Valves, Powell warrants to Purchaser that the Parts and/or Valves, as applicable, of its own manufacture are free of defects in material and workmanship, under normal use and proper operation. If any such Products fail to comply with such warranty, Powell, at Powell's option, shall either: (i) replace such defective Products; (ii) furnish replacement parts for repairing Products (iii) issue written authorization for Purchaser or others to replace or repair, without charge to Purchaser, at costs comparable to Powell's normal manufacturing costs, those parts proven defective; or (iv) refund all monies paid by Purchaser to Powell for such Products and, at the sole discretion of Powell, have the Products returned to Powell at Powell's expense. Finished materials and accessories purchased from other manufacturers are warranted only to the extent of the manufacturer's warranty to Powell (to the extent transferable by Powell to Purchaser). Any alteration in material or design of the Products or component parts thereof by Purchaser or others and/or the undertaking of repairs or replacement by Purchaser or its agents without Powell's written consent shall relieve Powell of all responsibility herewith.

Powell's obligations under this warranty shall be conditioned upon (a) Purchaser's notifying Powell of any alleged defect(s) in a writing that references Purchaser's Order number and provides complete identification of any allegedly defective Products within ten (10) days of the discovery of the damage or defect, and (b) Powell's satisfying itself upon inspection that its warranty has been breached. Purchaser may not bring any action under or arising from an Order or these Terms and Conditions unless such action is commenced within one year after the cause of action accrues.

EXCEPT AS SET FORTH IN THIS SECTION 17, POWELL MAKES NO WARRANTY CONCERNING THE PRODUCTS WHATSOEVER; POWELL DISCLAIMS AND EXCLUDES ALL OTHER WARRANTIES, EXPRESS OR IMPLIED, INCLUDING, WITHOUT LIMITATION, WARRANTIES OF NON-INFRINGEMENT AND THE IMPLIED WARRANTIES OF MERCHANTABILITY AND FITNESS FOR A PARTICULAR PURPOSE. THE OBLIGATIONS SET FORTH IN THIS SECTION 17 ARE POWELL'S SOLE OBLIGATIONS AND PURCHASER'S EXCLUSIVE REMEDY. POWELL SHALL NOT BE LIABLE FOR ANY DIRECT, INDIRECT, INCIDENTAL OR CONSEQUENTIAL DAMAGES, AND PURCHASER HEREBY WAIVES, FOR ITSELF AND ITS SUCCESSORS AND ASSIGNS, (A) ANY AND ALL CLAIMS FOR PUNITIVE DAMAGES AND (B) ALL CLAIMS OF NEGLIGENCE OR STRICT LIABILITY OR BOTH, WITHOUT LIMITATION TO THE FOREGOING, IN NO EVENT SHALL POWELL BE LIABLE FOR THE LOSS OF USE OF THE PRODUCT OR FOR THE LOSS OF USE OF ANY OTHER PRODUCT, PROCESS, EQUIPMENT, OR FACILITIES OF PURCHASER OR OF THE END-USER, WHETHER PARTIALLY OR WHOLLY DUE TO DEFECTS IN MATERIAL AND/OR WORKMANSHIP AND/OR DESIGN OF POWELL'S PRODUCT, AND IN NO EVENT SHALL POWELL BE LIABLE FOR REMOVAL OF APPURTENANCES OR INCIDENTALS SUCH AS CONNECTIONS, PIPE WORK AND SIMILAR ITEMS OF OBSTRUCTION OR FOR ANY COSTS BROUGHT ABOUT BY NECESSITY OF REMOVING THE PRODUCT FROM ITS POINT OF INSTALLATION.

Purchaser (a) recognizes that the limitations contained in this Section 17 are material factors in Powell's sale of the Products at the price(s) specified, and (b) agrees that any accommodation to Purchaser by Powell, whether for sales policy reasons or otherwise, shall not be taken to establish any liability of Powell or any contract term inconsistent with this Agreement.

Purchaser shall neither make nor purport to make (a) any warranty to any person by or on behalf of Powell or (b) any warranty or representation inconsistent with this Section 17.

18. COMPLIANCE WITH LAWS: Powell certifies that the Products produced by it, if any, were produced in compliance with all applicable requirements of Sections 6, 7 and 12 of the Fair Labor Standards Act of 1938, as amended, and the Regulations and Orders of the Administrator of the Wage and Hour Division issued under Section 14 thereof.

Powell shall endeavor to comply with all applicable Ohio and United States federal laws. Powell is not responsible for compliance with any other laws or regulations, or with any Product standard or specification, whether of general or particular application, unless Purchaser has furnished specific written notice thereof prior to Powell's entry of Purchaser's Order.

All sales of Products are conditioned upon and subject to strict compliance with United States export control laws, rules and regulations, including, without limitation, the Export Administration Act, the Export Administration Regulations, the Arms Control Act, the International Traffic in Arms Regulations, the Trading With the Enemy Act, the International Economic Powers Act and the Foreign Assets Control Regulations, as they may be amended and supplemented from time to time (each, an "Export Law" and collectively, the "Export Laws"). For any sale of Products requiring a license, permit or other approval under any Export Law ("Restricted Products"), Powell shall determine the feasibility of obtaining such license, permit or other approval ("Export Approval") and whether it will fill the order for the Restricted Products in light of required Export Approval. In the event Powell applies for Export Approval for the Restricted Products, it shall do so at Purchaser's cost and expense and Purchaser agrees to reimburse Powell for any cost or expenses (including Powell's reasonable attorneys' fees) incurred by Powell in pursuing Export Approval. Powell shall not be under any obligation to ship any such Restricted Products unless and until such Export Approval is granted, and only in strict compliance with the terms and conditions of such Export Approval. Purchaser shall be responsible for timely obtaining and maintaining any required import license, permit or approval necessary to import any Restricted Products into Purchaser's country and any other required governmental authorization ("Import Approval"). Powell shall not be liable if any Export Approval or Import Approval is delayed, denied, revoked, restricted or not renewed, and Purchaser shall not be relieved thereby of its obligations to pay Powell for the Restricted Products or Powell's costs and expenses of obtaining Export Approval in respect of Restricted Products under the Export Laws.

For Products other than Restricted Products, Purchaser (or its designated export agent) shall be responsible for the timely application for any required export authorization and the payment of any required fees, duties, taxes, tariffs, levies or other charges necessary to export the Products out the United States of America and shall be responsible for timely obtaining and maintaining any required Import Approval and the payment of any required fees, duties, taxes, tariffs, levies or other charges necessary to import the Products into Purchaser's country. Powell shall not be liable if any export authorization or Import Approval is delayed, denied, revoked, restricted or not renewed, and Purchaser shall not be relieved thereby of its obligations to pay Powell for the Products.

Purchaser shall not make any disposition of any Products purchased hereunder, by way of transshipment, reexport, diversion or otherwise, other than in and to the ultimate end user and country of destination specified on Purchaser's order or declared as the ultimate end user and country of ultimate destination on Powell's invoices, except as the Export Laws or Export Approval may expressly permit. Purchaser shall not distribute or resell any Product to or within any country or to any individual, government authority or other entity that is presently or at any time in the future subject to sanctions of the United States government, or is in violation of any Export Laws or other United States federal laws, statutes, codes, Executive Orders, decrees, rules or regulations relating to terrorism, drug trafficking or money laundering, or is designated under any such authority as being subject to sanctions or connected in any way to terrorism, drug trafficking or money laundering, including, without limitation, on the Specially Designated Nationals List and Block Persons List maintained by the Office of Foreign Assets Control (OFAC), United States Department of the Treasury, and the Denied Persons List, the Entity List and the Unverified List maintained by the Bureau of Industry and Security, United States Department of Commerce.

Purchaser shall indemnify and hold harmless Powell from and against any damages, liabilities or expenses of any kind incurred by Powell as a result of Purchaser's direct or indirect breach of any term or condition related to the Export Laws.

19. SAFETY: Purchaser warrants that it will comply with all laws, regulations, standards and requirements which are applicable to the use of the Products and Purchaser's business.

20. CONFIDENTIALITY: Purchaser will not disclose or otherwise disseminate, directly or indirectly, any of the terms of these Terms and Conditions or any other information of Powell given to or received by Purchaser or its associates or agents, unless Purchaser received Powell's written permission or such information is required to be disclosed by law or becomes part of the public domain through no fault of Purchaser, its associates or agents.

21. GOVERNING LAW; JURISDICTION AND VENUE: These Terms and Conditions shall be governed by and construed in accordance with the internal laws of the State of Ohio, without regard to such state's choice of law principles. These Terms and Conditions shall not be governed by or construed in accordance with the United Nations Convention on the International Sale of Goods, 1980, for any purpose. Customer and Powell hereby submit to the jurisdiction and venue of the state and federal courts in Cincinnati, Hamilton County, Ohio over any controversy relating to or arising from these Terms and Conditions. Notwithstanding the foregoing, Powell's right to institute or defend any proceedings in any jurisdiction, in or out of the United State of America, shall not be limited.

22. SEVERABILITY: If any of the provisions of these Terms and Conditions are deemed invalid, illegal or unenforceable, the validity, legality and enforceability of the remaining provisions will in no way be affected or impaired thereby.

23. FORCE MAJEURE: Delivery of all or any part of the Products is contingent upon Powell's ability to obtain supplies, raw materials and services through its regular and usual sources of supply. If by reason of any contingency beyond Powell's reasonable control, including (but not limited to) war, governmental requests, restrictions or regulations, fire, flood, casualty, accident, or other acts of God, strikes or other difficulties with employees, delay or inability to obtain labor, equipment, material and services through Powell's usual sources, failure or refusal of any carrier to transport materials, delay in transport thereof, or any other similar occurrence, Powell is not able to meet anticipated deliveries, Powell shall not be liable therefore and may, in its discretion without prior notice to Purchaser, postpone the delivery date(s) under this document for a time which is reasonable under all the circumstances. If during the occurrence of any of the foregoing contingencies, Powell holds any of the Products, Powell may invoice and hold the same for the account of Purchaser and Purchaser agrees to make payment at the maturity of the invoice so rendered.

24. ASSIGNMENT: No right or interest in the contract arising from these Terms and Conditions shall be assigned by Purchaser and no delegation of any obligation owed by Purchaser shall be made without the prior written permission of Powell. As used herein, "Purchaser" and "Powell" include the respective heirs, executors, personal representatives, successors and permitted assigns of each.

25. REMEDIES CUMULATIVE; NO WAIVER: The individual rights and remedies of Powell reserved herein shall be cumulative and additional to any other or further remedies provided in law or equity or in this document. Waiver by Powell of performance or breach of any provision hereof by Purchaser, or failure of Powell to enforce any provision hereof which may establish a defense or limitation of liability, shall not be deemed a waiver of future compliance therewith or a course of performance modifying such provision, and such provision shall remain in full force and effect as written.

26. LIMITATION OF LIABILITY: UNDER NO CIRCUMSTANCES SHALL POWELL BE LIABLE TO PURCHASER UNDER OR IN CONNECTION WITH ORDERS FOR PRODUCTS AND THESE TERMS AND CONDITIONS, WHETHER ANY CLAIM FOR RECOVERY IS BASED UPON OR ARISES OUT OF THEORIES OF BREACH OF CONTRACT, BREACH OF WARRANTY, INDEMNIFICATION, NEGLIGENCE, TORT (INCLUDING STRICT LIABILITY) OR OTHERWISE, IN EXCESS OF AN AMOUNT EQUAL TO THE NET CONTRACT VALUE OF THE PRODUCTS PROVIDED BY POWELL TO PURCHASER DURING THE MOST RECENTLY ENDED CALENDAR QUARTER.

POWELL
VALVES

Established 1846



POWELL VALVES

2503 SPRING GROVE AVENUE, CINCINNATI, OHIO 45214-1771, U.S.A.

PHONE 513.852.2000 • FAX NO. 513.852.2997

www.powellvalves.com