

A photograph of a male worker in profile, wearing a white hard hat with a logo and safety glasses. He is wearing a light blue long-sleeved shirt and is holding a laptop computer. He is standing in front of a complex industrial control station for a gas distribution network. The station includes various pipes, valves, gauges, and electrical control boxes. In the background, there is a chain-link fence and a white vehicle. The sky is clear and blue.

**Take control of your gas
distribution network**

Overpressure Protection Solutions (OPP)

Proven automation solutions and local expertise to help you overcome your toughest challenges





Courtesy of Enbridge Gas, Inc.

How do you determine the right pressure protection for your distribution network?

Any natural gas incident, no matter the size, is one incident too many. While a single level of overpressure protection (OPP) is prevalent among gas distribution operators, a second or even third level of protection is gaining importance to ensure that customers and assets are completely protected.

But who do you turn to when deciding what level you need and if protection levels are properly positioned? Do you need clarity around applicable regulations, available solutions portfolio and training for personnel upskilling?

Safety will always be the number one priority for the natural gas industry. In addition, upskilling personnel, complying with changing regulations and selecting reliable partners are pressing challenges.

“Natural gas utilities spend \$22 billion annually to help enhance the safety of natural gas distribution and transmission systems.”
- American Gas Association



The Natural Gas distribution industry states 23% of the workforce is over the age of 55.
- U.S. Bureau of Labor Statistics



“Many large utilities now spend multiple billions of dollars each year on suppliers, amplifying traditional risks.”
- BCG.com, How Utilities Can Manage Supplier Risk



Emerson – Your safety and reliability partner

While the gas distribution system is comprised of many components, mechanical devices like **regulators, pressure relief valves, slam-shuts** and **isolation valves** provide the last line of defense against overpressurizing the delivery lines. **Real-time monitoring** and **control** adds the ability to quickly collect and analyze gas distribution system data to respond to unusual events. Our scalable solutions can improve your network efficiency, reliability and safety to help mitigate overpressure or underpressure events.



Partner with a global leader with proven industry expertise

- Emerson is a global leader in pressure control with innovative, reliable and robust products in the world's most rugged environments
- Extensive experience with utilities, providing solutions for uninterrupted, safe and accurate delivery of natural gas
- Globally recognized R&D facilities, testing centers and manufacturing facilities that design and deliver exceptional solutions

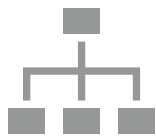

Reduce complexity without sacrificing flexibility

- Extensive product portfolio to suit your network's OPP requirements
- Modular and customizable options to meet specific applications and operating conditions
- Eliminate supplier inefficiencies by partnering with a global leader that provides the complete solution



Minimize risk associated with regulatory compliance

- Knowledgeable industry experts to help you navigate impending regulations and ensure compliance
- Scalable solutions that can accommodate requirements as regulations evolve in the future
- A well-connected Partner network providing global as well as localized expertise



Upskill personnel through tailored training options and lifecycle services

- Technical expertise to help aid your organization in the selection and implementation of OPP solutions
- Tailored learning opportunities available, and established robust training programs through Emerson and our partner network
- Network of support specialists available for product lifecycle management

A complete portfolio of overpressure protection solutions

Protect

The primary concern is to avoid an overpressurization incident in the natural gas delivery system. Protecting people, assets and equipment is paramount and Emerson's suite of mechanical solutions is designed to accurately function in narrow pressure ranges and multiple product combinations.

Choosing options for an overpressure/ underpressure protection system involves multiple levels of decision making:

- How will the additional solution interact with the already existing system?
- Can it be retrofitted / is it a new system / are there space constraints?
- What is the last line of defense to ensure system protection?











Monitor and Control

Strategically placing pressure monitoring points throughout the distribution network assists with on-time alerts and triggers prompt reactive measures. Any overpressure or underpressure events can be handled remotely through our configurable control solutions, ensuring a centralized and more efficient response.

Choosing a monitoring/control system to compliment your primary protection devices raises additional considerations:

- Can it be remotely verified that the primary protection method is operational?
- Are changes needed to monitoring and alarming to improve response times?
- What communication infrastructure exists today? Future?
- How will data be stored and accessed in order to meet regulatory requirements?

LEGEND

-  REGULATOR
-  REGULATOR AND INTEGRAL SLAM-SHUT
-  TOKEN RELIEF VALVE
-  FULL CAPACITY RELIEF VALVE
-  SLAM-SHUT
-  RTU OR FLOW COMPUTER WITH TELEMETRY
-  ODORIZATION
-  METER
-  GAS CHROMATOGRAPH
-  EFM

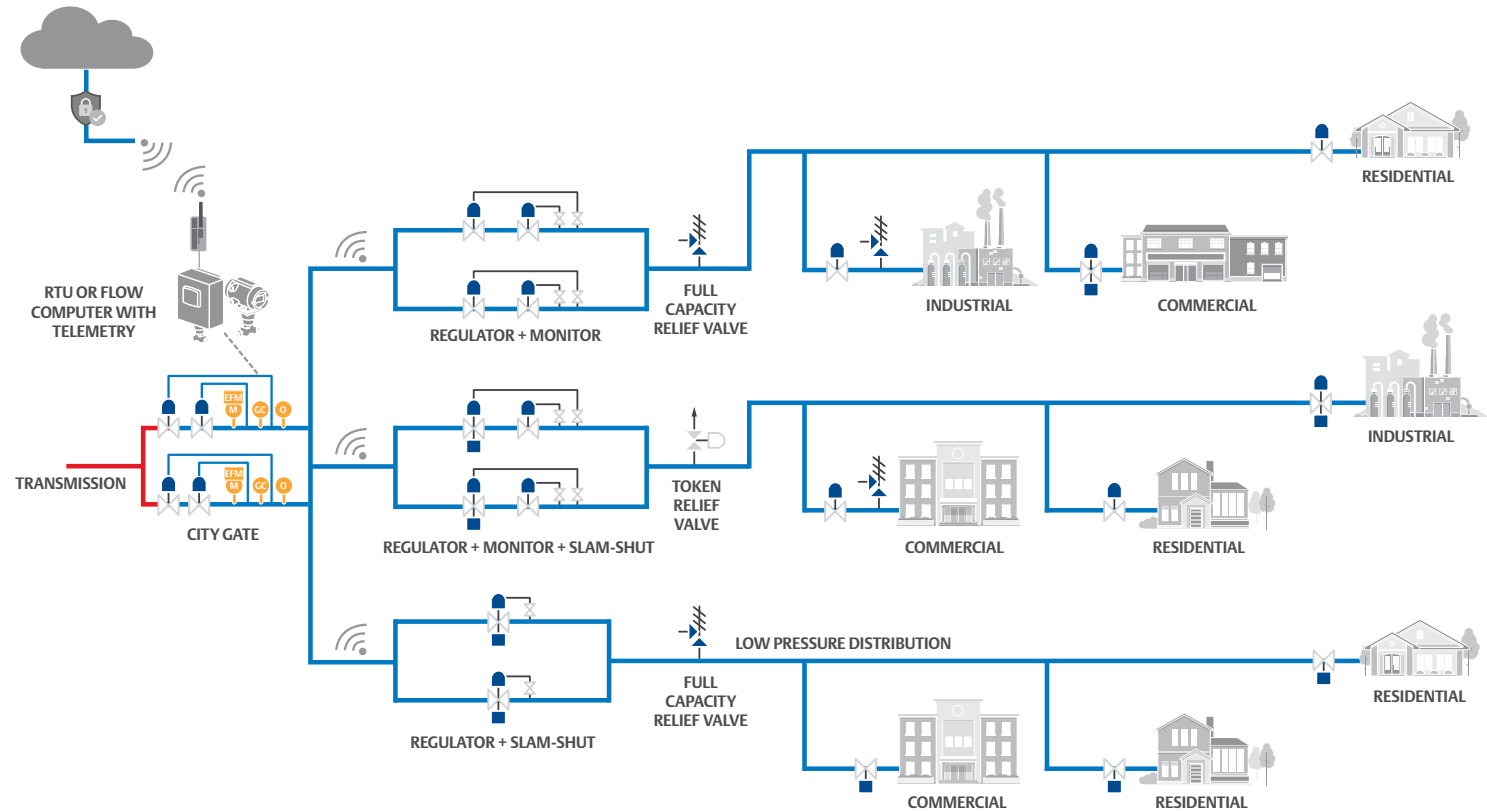



Protect

Take the next step to protect your distribution network by upgrading to a second level of protection:

- **Regulator Monitor with Full Capacity Relief:** Any two regulators in series and a pressure relief valve, all sensing the same downstream pressure. The monitor regulator provides the first level of protection and the relief valve provides the second level. > p6
- **Regulator Monitor with Slam-shut:** Any two regulators in series and a slam-shut valve, all sensing the same downstream pressure. The monitor regulator provides the first level of protection and the slam-shut provides the second level. > p8
- **Regulator, Slam-Shut and Full Capacity Relief:**
A regulator, slam-shut and relief valve, all sensing the same downstream pressure. The relief valve provides the first level of protection and the slam-shut provides the second level. > p8

Monitor and Control

Independent of primary protection devices, monitoring options provide deeper insights to your system's performance and increases the overall system safety.

- **General Monitoring and Recording:** Combine FB Series flow computers with Rosemount™ pressure transmitters to achieve real-time capture, storage and communication of overpressure events. > p10
- **Advanced Monitoring, Control and Flow Measurement:** Maximize the functionality of FB Series flow computers by integrating valves and primary flow meters from Emerson's product range for a single-source solution. > p10
- **Automated Isolation Valves:** Ensure tight shut-off even from a remote location. > p10
- **SCADA Monitoring:** Emerson provides a range of SCADA solutions to monitor, control and accomplish more with greater visibility of your system. > p12

Protect your people, assets and reputation

A monitor system is a common option for single layer overpressure protection. This system is comprised of any two regulators in series both sensing the same downstream pressure. Upon the failure of one regulator, the other regulator will continue to maintain the downstream pressure. > p7

Another common method for single layer overpressure protection is a regulator with a full capacity relief. These system are comprised of a single regulator controlling downstream pressure and a relief valve downstream of the regulator monitoring downstream pressure. Upon a failure of regulator, the relief valve will open relieving excess pressure to maintain the downstream pressure below the maximum allowable operating pressure. > p7

A monitor system or a regulator and relief system as the first overpressure protection method offers maximum flexibility for adding a second level of protection. Depending on your existing system and based on considerations like footprint, emissions and service continuity, the second level can include the addition of a full capacity relief valve, a slam-shut or a monitor regulator.

Regulator Monitor with Full Capacity Relief

Upgrading a monitor system by including a full capacity relief will add an additional layer of overpressure protection by relieving excess gas if the regulator monitor system is unable to maintain a safe system pressure.

Pressure Relief Valves (PRVs) are designed to open during an overpressure event and ensure uninterrupted natural gas service while maintaining a safe pressure in the downstream piping. Emerson offers Fisher™ and Anderson Greenwood™ Pilot-Operated PRVs for both high pressure and utilization pressure distribution applications with live monitoring capabilities. > p7

Advantages

- Maintains a safe downstream pressure
- Uninterrupted natural gas service
- Modulating action available to minimize natural gas vented to atmosphere
- Best-in-class seat tightness eliminates fugitive emissions during normal operation meeting or exceeding ANSI/FCI Class VIII shut-off
- More flow volume per line size reduces the size of the regulator to achieve maximum flow

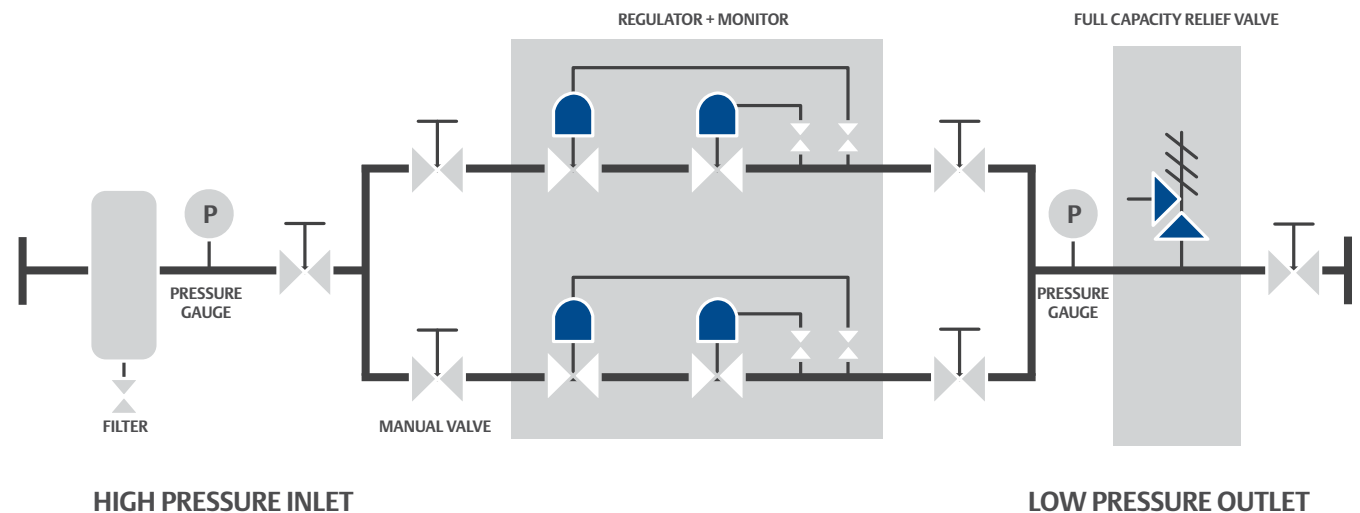

Regulator Monitor Systems

Fisher™ Type EZL

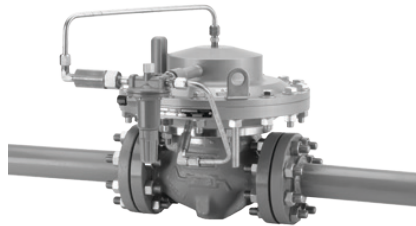

- Pilot-operated; plug style regulator
- Low minimum differential: 2.9 psid/0.2 bard
- Precise pressure control: stable and accurate downstream pressure control
- Top entry, easy in-line maintenance
- Inlets up to 290 psig
- Control range: 0.25 to 287 psig

Fisher Type EZR



- Pilot-operated, flexible element regulator
- Top-entry design allows easy in-line maintenance
- Protected flexible element
- Top entry, easy in-line maintenance
- Maximum differential pressure: 800 psid
- Control range: 6 in. w.c. to 1000 psig

Fisher Type 299H



- Pilot-operated, plug style regulator
- Low minimum differential: 1.5 psid
- Precise pressure control
- External, internal or dual registration
- Easy startup and maintenance
- Control range: 3.5 in. w.c. to 60 psig

Section VIII Pressure Relief Valves

Anderson Greenwood™ 200 Series Pilots



- Set pressures from 15 to 10,000 psig
- Sizes from 1 to 10 in.
- Snap action pilot achieves full lift at set pressure (0% buildup)
- Adjustable reseal from 3 to 15% below set pressure
- Non-flowing pilot design

Anderson Greenwood 400 Series Pilots



- Set pressures from 15 to 1480 psig
- Sizes from 1 to 10 in.
- Modulating action pilot minimizes gas lost during reliefs
- Full lift at 10% overpressure/buildup
- High Gain option available (full lift at 5% overpressure/buildup)
- Fixed blowdown of 4% below set pressure
- Non-flowing pilot

Anderson Greenwood Series 9300 Pilots



- Set pressures from 3 in. w.c. to 50 psig
- Sizes from 2 to 14 in.
- Zero leakage up to set pressure
- Field adjustable for snap (0%), modulating action (10%), or high gain (5% buildup) opening action
- The 9300 offers up to 15% more flow than highest relief capacity per line size

Non-Section VIII Relief Valves

Fisher EZR Relief

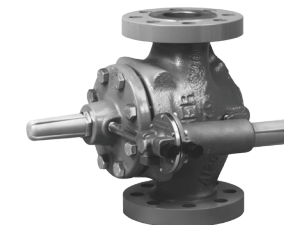

- Set pressures from 20 to 1160 psig
- Top-entry design allows easy in-line maintenance
- Specially engineered flow path reduces operational noise
- 100% of published flow capacities can be used with confidence

Protect your people, assets and reputation

Regulator Monitor with Slam-Shut

Adding a slam-shut valve to a monitor system creates an additional layer of overpressure protection by completely shutting off the system supply if your regulator monitor system is unable to maintain a safe system pressure.

Slam-shut valves are designed to rapidly shut-off the gas flow when the pipeline pressure exceeds or falls below predefined levels. Emerson offers both standalone slam-shuts and integral regulator/slam-shut combinations that utilize a common body where the slam-shut is able to act independently of the regulator. > p9

Advantages

- Maintains a safe downstream pressure
- Environmentally friendly with no leaking or venting to atmosphere
- ANSI / FCI Class VIII bubble-tight shut-off
- Easy in-line maintenance
- Trip mechanism designed with accuracy, repeatability and vibration resistance to avoid unintentional trips

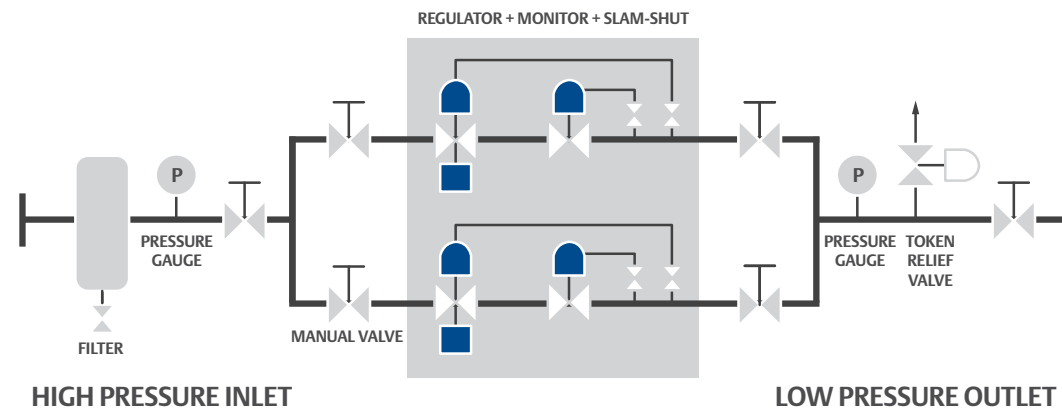

Regulator, Slam-Shut and Full Capacity Relief

The combination of a regulator, full capacity relief and a slam-shut valve will provide two levels of overpressure protection. If your regulator and relief system is unable to maintain a safe system pressure the slam-shut valve will completely shut off the pressure to the system.

Using the regulator, relief and slam-shut option offers a unique method of overpressure protection using varying pressure protection technologies. > p9

Advantages

- Maintains a safe downstream pressure
- Uninterrupted natural gas service during one failure with a last line of defense system shutdown if a catastrophic event occurs
- ANSI / FCI Class VIII bubble-tight shut-off
- Diversity in pressure control technologies, aiding risk mitigation

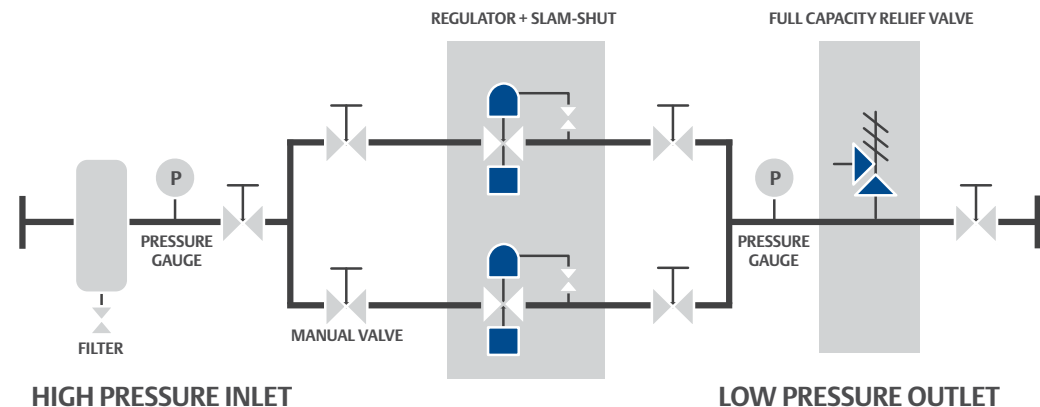

Slam-Shut Devices

Fisher™ Type OSE



- Overpressure and underpressure protection
- High shock and vibration resistance – two-stage tripping mechanism
- Maintains up to $\pm 1\%$ accuracy regardless of inlet pressure, flow rate and size of slam-shut
- Designed to EN 14382
- Option to integrate into EZR, EZL and EZH regulators
- Range: 4 in. w.c. to 1058 psig

Fisher Type VS100



- Medium to high capacity stand alone slam-shut
- Quick response time
- Designed to EN 14382
- Complies with PED (97/23/EC) Requirements
- Option to integrate into Commercial Service Regulator Series and 299H regulators
- Range: 12 in. w.c. to 79.8 psig

Fisher Type CSB704



- Direct-operated, spring-loaded regulator
- Balanced trim design improves accuracy
- Inlet rating: 232 psi
- Control range: 0.13 to 58 psig
- Integrated VSX slam-shut designed to EN 14382

Additional Pressure Protection Solutions

Fisher Integral True-Monitor

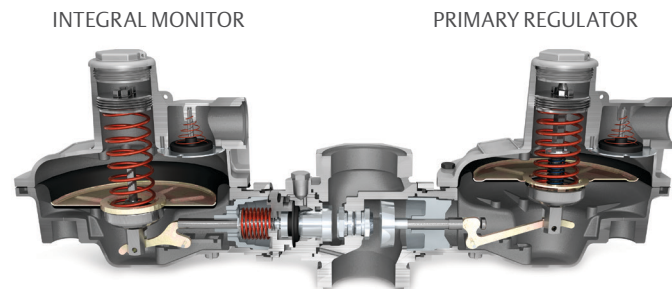

- Available on Commercial Service Regulator Series
- Provides the True Monitor™ protection, combining the operation of a conventional two-regulator wide-open monitor set into one device without the need for a downstream control line
- Offers increased outlet setpoint capabilities
- Ability to easily adjust setpoint in the field
- Integral monitor has minimal capacity reduction

Fisher CS800IQ

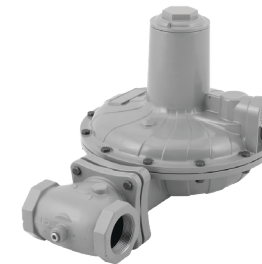

- High capacity internal relief eliminates the need for an external relief valve
- Reduces equipment and maintenance costs
- Application versatility
- High turndown capabilities to satisfy varying flow requirements
- Range: 3.5 in. w.c. to 10 psig
- Option to add integral slam-shut or True Monitor™

Monitor and control for safe system operations

General Monitoring and Recording

Gain greater visibility of your station by combining FB Series products with strategically located Rosemount™ pressure transmitters, to achieve real-time capture, storage and communication of over pressure events.

Advantages

- Configurable alarm levels: LL, L, H, HH and Rate of Change
- History, alarms and events logging including time stamp
- Monitor and record pressure, temperature and other site data in the same device
- Supports multiple protocols for easy integration to any existing or new SCADA system
- Secure and simple access to recorded data, locally as well as remotely using new applications

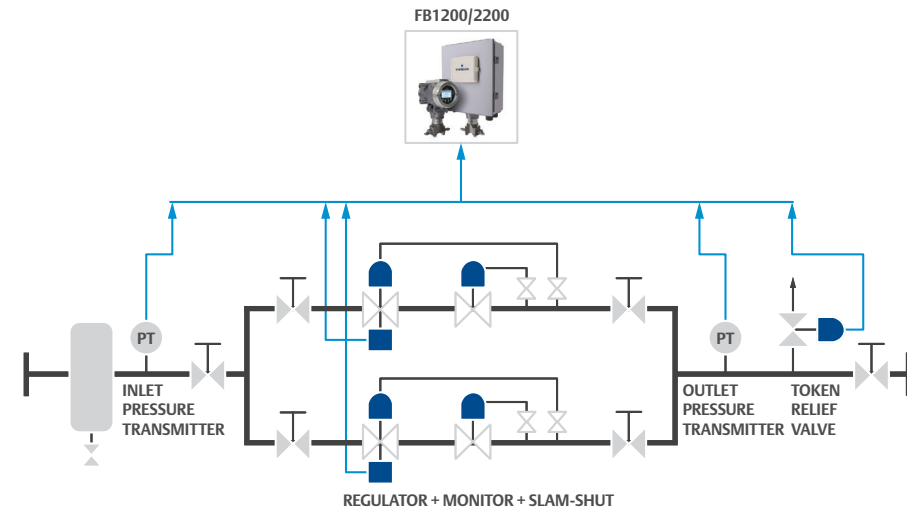

Advanced Station Monitoring, Control and Flow Measurement

Maximize the functionality of Emerson's FB Series flow computers to bring control and flow measurement capability to your operations. Integration with valves and primary flow meters from Emerson's product range provides a value-driven, single-source solution.

Advantages

General monitoring and recording advantages, plus the following:

- Capability to generate local alerts: light and sound
- Capability to control a valve automatically and/or remotely when needed
- Capability to perform custody transfer flow measurement of natural gas
- Full audit trail to know the answers to difficult questions in critical times: who, what and when?
- Complete station monitoring and control in a single FB Series flow computer

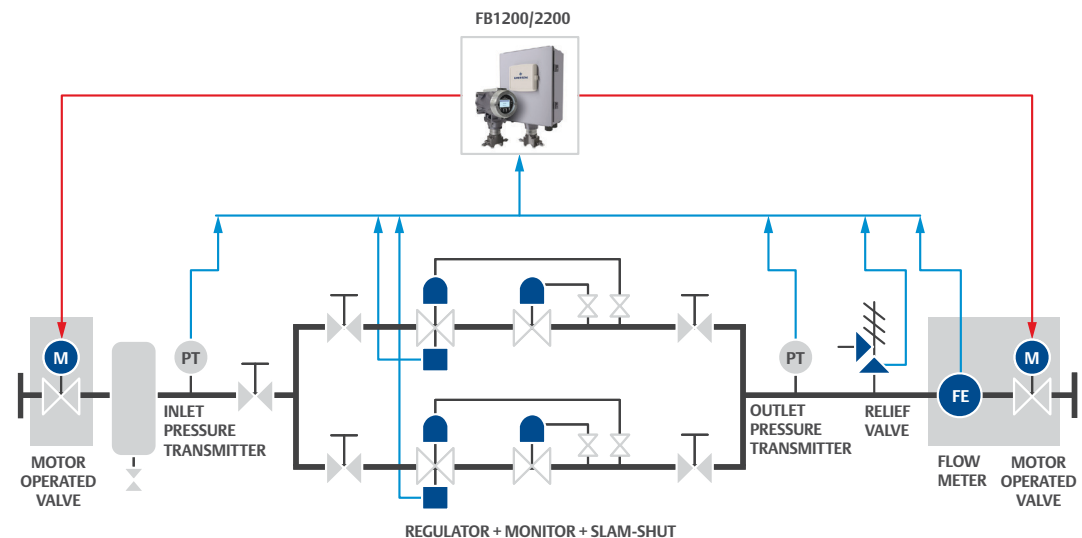

Monitor and Control

Rosemount™ 3051 In-Line Pressure Transmitter



- Support ranges 0-3 psi up to 4000 psi with 0.04% accuracy.
- Reduce maintenance with 10-year stability
- Loop Integrity diagnostics
- Easy commissioning and configuration with local operator interface
- Gain insight into remote operations and eliminate wiring costs with WirelessHART

FB1000 and FB2000 Series Flow Computers



- Measurement ready 1 or 2 meter runs
- Integral MVS (DP or SP) transducer
- Inputs and Outputs: RTD, AI/AO, DI/DO/PI
- Communication: 3 x Serial, 1 x Ethernet, 1 x FBxWifi™
- Protocols: DNP3, Modbus, BSAP, ROC
- Data Logging: Alarms, Events and History
- PID and Control Logic
- C1 D1 (FB1000 Series) and C1 D2/ Zone 2 (FB2000 Series)

FB3000 Remote Terminal Unit



- Measurement ready up to 24 meter runs
- 7 slots of I/O cards in standard chassis
- Add up to 3 chassis for increased I/O
- Communication: 2 x Ethernet, 4 x Serial
- Protocols: DNP3, Modbus
- Data Logging and History
- PID and Control Logic
- IEC61131 Programming and Applications
- C1 D2/ Zone 2

BETTIS TorqPlus Electric Valve Actuator



- Robust, easy to service, quarter-turn electric actuator
- Torque from 8 ft lbs / 11 Nm to 1667 ft lbs / 2260 Nm
- Certified explosion and weatherproof
- Available with local push button controls

KTM Ball Valves



- Positive shut-off with KTM E-Seat®
- Up to 932F with KTM Gratiite® and Metaltite® seats
- Live loaded packing standard
- Fugitive emission certified to API 641 and ISO 15848-1
- Blow out proof stem
- Integral ISO 5211 mounting pad
- SIL3 capable
- Fire safe design certified to API 607
- Conforms to ASME B16.34 and PED

Increase your system wide visibility through SCADA monitoring

SCADA systems provide scalable system monitoring, from single sites to thousands of monitoring points, with easy integration of remote field devices. Emerson provides a wide range of SCADA solutions.

Existing Host networks

- Products designed with flexible protocol connectivity to adapt to existing SCADA networks
- Remote storage concepts protect data in cases of Host connectivity issues to ensure access to information

On-Premise Host solutions

- Our robust SCADA offering, OpenEnterprise™ collects, stores and visualizes your infrastructure
- Internal asset tools, comprehensive trending and workflow modeling compliments control room activity

Off-Premise Cloud Based Host solutions

- Cloud based hosting offers an option to replace or supplement on-premise SCADA for reduced total cost of ownership
- Standard SCADA functionality is enhanced by a cloud based network through simplified maintenance and improved networkability



OpenEnterprise™ On-Premise Host Solution

- A highly-scalable client server architecture for distributed SCADA installations
- Seamless integration to field devices
- Integrated historian with backfill capability
- Supports flexible architecture for redundancy and back up control rooms
- Operator notes for collaboration and logging event-specific information
- Powerful reporting and trending tools
- Alarm and event manager, with text messaging and e-mail support
- Open standards facilitates easy integration to business systems

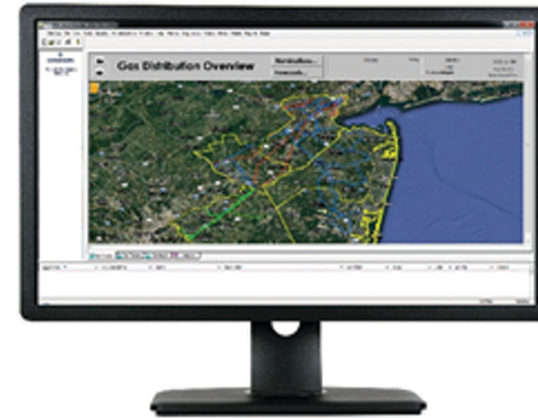

Zedi Access™ Cloud Based Host Solution



- Subscription based cloud SCADA service with evergreen enhancements, secure storage and full support
- Unlimited users, no seats or site licenses required
- Anytime, anywhere remote access via Mobile App or Internet Web Browser
- Application specific templates
- Alarm management and automated call out alarm system
- Data archiving and retrieval

Zedi Go App for Mobility



- Access via smart phones and tablets
- Easily view trend graphs of recent performance
- Prioritize work in the field based on current alarm information
- Automatically push data to other systems or to custom reports
- Manually input data, change settings and issue commands
- Demand poll from mobile device for on-the-go, live updates

Continuous support in the face of changing regulations

Our partnership does not end with an extensive portfolio of solutions. Emerson helps to maximize your investment with industry-defining end-to-end support for education, training and lifecycle services. Improve your workforce with a full range of training options from Emerson's Educational Services. Need some help with startup on a complex project, or maintenance to keep your gas network operating safely, reliably and economically? Our Lifecycle Services can provide support and expertise.

Education and Training

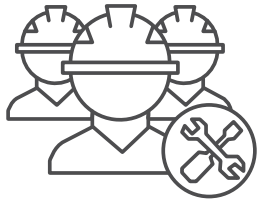

Leverage our educational offerings to train new hires, upskill your current workforce or help your team adapt to new technology or products.

- Courses are a blend of onsite, e-learning and virtual classroom modules
- Engage with industry experts at a location and time that works best for you
- Our virtual classroom delivers real-time, value-based instructor led training to your desktops, no traveling required
- We also offer courses at Emerson training centers located strategically around the world

Lifecycle Services

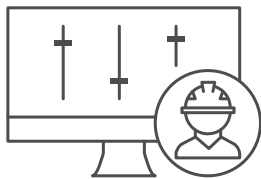

Emerson Lifecycle Services provides customers with the expertise, technology and processes that can help you operate safely, improve asset reliability and optimize gas distribution.

- Service support to execute the maintenance strategy that best suits your operation and budget
- Emerson's local service centers and global network offer a wide inventory of factory-certified parts
- Startup and commissioning services to aid in a safe, timely startup of your process
- Assess the reliability, security and performance of your assets using our site walkdown and evaluation services





With locations worldwide, Emerson local experts are never far away. Get in touch today to arrange a site walk and see the value Emerson can bring to your operation.

Resolve your OPP challenges with a partner you can trust



Emerson delivers time-tested and innovative overpressure protection solutions for your natural gas distribution systems. Contact us now for world-class technologies and services that can help you protect your customers and assets and gain oversight of your distribution systems.

Visit [Emerson.com/OverpressureProtection](https://www.emerson.com/OverpressureProtection)

Emerson Electric Co.
Global Headquarters
8000 West Florissant Avenue
St. Louis, Missouri, 63136
United States
T +1 314 679 8984
ContactUs@Emerson.com
Emerson.com/FinalControl

Emerson Automation Solutions
Latin America Headquarters
1300 Concord Terrace Suite 400
Sunrise, Florida 33323
United States
T +1 954 846 5030

Emerson Automation Solutions
Europe Headquarters
Neuhofstrasse 19a P.O. Box
1046 CH 6340 Baar,
Switzerland
T +41 41 768 6111

Emerson Automation Solutions
Middle East and Africa Headquarters
Emerson FZE P.O. Box 17033,
Jebel Ali Free Zone - South 2
Dubai, United Arab Emirates
T +971 4 81 18100

Emerson Automation Solutions
Asia Pacific Headquarters
1 Pandan Crescent
Singapore 128461
T +65 6777 8211

D353095X012 © 2020 Emerson Process Management Regulator Technologies, Inc. All rights reserved. 07/20.
The Emerson logo is a trademark and service mark of Emerson Electric Co. All other marks are the property of their prospective owners.



CONSIDER IT SOLVED.™